

# SECTION **SRC**

## SRS AIRBAG CONTROL SYSTEM

A  
B  
C  
D  
E  
F  
G  
H  
I  
J  
K  
L  
M  
N  
O  
P

### CONTENTS

<b>BASIC INSPECTION</b> .....	5	DTC Logic .....	22
<b>DIAGNOSIS AND REPAIR WORK FLOW</b> .....	5	Diagnosis Procedure .....	22
Work Flow .....	5	<b>B1011, B1012, B1013, B1014, B1015 DIAG-</b>	
<b>SYSTEM DESCRIPTION</b> .....	7	<b>NOSIS SENSOR UNIT</b> .....	24
<b>SRS AIR BAG SYSTEM</b> .....	7	Description .....	24
System Diagram .....	7	DTC Logic .....	24
System Description .....	7	Diagnosis Procedure .....	24
Component Parts Location .....	8	<b>B1017, B1020, B1021 OCCUPANT SENS C/U</b>	
Component Description .....	9	.....	26
<b>OCCUPANT CLASSIFICATION SYSTEM</b> .....	10	Description .....	26
System Diagram .....	10	DTC Logic .....	26
System Description .....	10	Diagnosis Procedure .....	26
Component Parts Location .....	10	<b>B1018 OCCUPANT SENS</b> .....	28
Component Description .....	11	Description .....	28
<b>PASSENGER SEAT BELT WARNING SYS-</b>		DTC Logic .....	28
<b>TEM</b> .....	12	Diagnosis Procedure .....	28
System Diagram .....	12	<b>B1022 OCCUPANT SENS C/U</b> .....	30
System Description .....	12	Description .....	30
Component Parts Location .....	13	DTC Logic .....	30
Component Description .....	13	Diagnosis Procedure .....	30
<b>DIAGNOSIS SYSTEM (AIRBAG)</b> .....	14	<b>B1023 PASS A/B INDCTR CKT</b> .....	32
Diagnosis Description .....	14	Description .....	32
Air Bag Warning Lamp Diagnosis .....	14	DTC Logic .....	32
CONSULT-III Function .....	18	Diagnosis Procedure .....	32
<b>DTC/CIRCUIT DIAGNOSIS</b> .....	20	<b>B1026, B1027, B1028, B1029, B1030, B1031</b>	
<b>B1001, B1002, B1003, B1004, B1005 DIAG-</b>		<b>DIAGNOSIS SENSOR UNIT</b> .....	34
<b>NOSIS SENSOR UNIT</b> .....	20	Description .....	34
Description .....	20	DTC Logic .....	34
DTC Logic .....	20	Diagnosis Procedure .....	34
Diagnosis Procedure .....	20	<b>B1033, B1034 CRASH ZONE SEN</b> .....	36
<b>B1006, B1007, B1008, B1009, B1010 DIAG-</b>		Description .....	36
<b>NOSIS SENSOR UNIT</b> .....	22	DTC Logic .....	36
Description .....	22	Diagnosis Procedure .....	36
		<b>B1035, B1036 CRASH ZONE SEN</b> .....	38

SRC

Description .....	38	<b>B1081 PRE-TEN FRONT RH .....</b>	<b>62</b>
DTC Logic .....	38	Description .....	62
Diagnosis Procedure .....	38	DTC Logic .....	62
		Diagnosis Procedure .....	62
<b>B1042, B1043, B1044, B1045, B1046, B1047</b>		<b>B1082 PRE-TEN FRONT RH .....</b>	<b>64</b>
<b>DIAGNOSIS SENSOR UNIT .....</b>	<b>40</b>	Description .....	64
Description .....	40	DTC Logic .....	64
DTC Logic .....	40	Diagnosis Procedure .....	64
Diagnosis Procedure .....	40		
<b>B1049, B1054 DRIVER AIRBAG MODULE .....</b>	<b>42</b>	<b>B1083 PRE-TEN FRONT RH .....</b>	<b>66</b>
Description .....	42	Description .....	66
DTC Logic .....	42	DTC Logic .....	66
Diagnosis Procedure .....	42	Diagnosis Procedure .....	66
<b>B1050, B1055 DRIVER AIRBAG MODULE .....</b>	<b>44</b>	<b>B1084 PRE-TEN FRONT RH .....</b>	<b>68</b>
Description .....	44	Description .....	68
DTC Logic .....	44	DTC Logic .....	68
Diagnosis Procedure .....	44	Diagnosis Procedure .....	68
<b>B1051, B1056 DRIVER AIRBAG MODULE .....</b>	<b>46</b>	<b>B1086 PRE-TEN FRONT LH .....</b>	<b>70</b>
Description .....	46	Description .....	70
DTC Logic .....	46	DTC Logic .....	70
Diagnosis Procedure .....	46	Diagnosis Procedure .....	70
<b>B1052, B1057 DRIVER AIRBAG MODULE .....</b>	<b>48</b>	<b>B1087 PRE-TEN FRONT LH .....</b>	<b>72</b>
Description .....	48	Description .....	72
DTC Logic .....	48	DTC Logic .....	72
Diagnosis Procedure .....	48	Diagnosis Procedure .....	72
<b>B1058, B1059, B1060, B1061, B1062, B1063</b>		<b>B1088 PRE-TEN FRONT LH .....</b>	<b>74</b>
<b>DIAGNOSIS SENSOR UNIT .....</b>	<b>50</b>	Description .....	74
Description .....	50	DTC Logic .....	74
DTC Logic .....	50	Diagnosis Procedure .....	74
Diagnosis Procedure .....	50		
<b>B1065, B1070 ASSIST A/B MODULE .....</b>	<b>52</b>	<b>B1089 PRE-TEN FRONT LH .....</b>	<b>76</b>
Description .....	52	Description .....	76
DTC Logic .....	52	DTC Logic .....	76
Diagnosis Procedure .....	52	Diagnosis Procedure .....	76
<b>B1066, B1071 ASSIST A/B MODULE .....</b>	<b>54</b>	<b>B1106, B1107, B1108, B1109, B1110, B1111</b>	
Description .....	54	<b>DIAGNOSIS SENSOR UNIT .....</b>	<b>78</b>
DTC Logic .....	54	Description .....	78
Diagnosis Procedure .....	54	DTC Logic .....	78
		Diagnosis Procedure .....	78
<b>B1067, B1072 ASSIST A/B MODULE .....</b>	<b>56</b>	<b>B1113, B1114 SATELLITE SENS RH .....</b>	<b>80</b>
Description .....	56	Description .....	80
DTC Logic .....	56	DTC Logic .....	80
Diagnosis Procedure .....	56	Diagnosis Procedure .....	80
<b>B1068, B1073 ASSIST A/B MODULE .....</b>	<b>58</b>	<b>B1115, B1116 SATELLITE SENS RH .....</b>	<b>82</b>
Description .....	58	Description .....	82
DTC Logic .....	58	DTC Logic .....	82
Diagnosis Procedure .....	58	Diagnosis Procedure .....	82
<b>B1074, B1075, B1076, B1077, B1078, B1079</b>		<b>B1118, B1119 SATELLITE SENS LH .....</b>	<b>84</b>
<b>DIAGNOSIS SENSOR UNIT .....</b>	<b>60</b>	Description .....	84
Description .....	60	DTC Logic .....	84
DTC Logic .....	60	Diagnosis Procedure .....	84
Diagnosis Procedure .....	60	<b>B1120, B1121 SATELLITE SENS LH .....</b>	<b>86</b>

Description .....	86	Description .....	110
DTC Logic .....	86	DTC Logic .....	110
Diagnosis Procedure .....	86	Diagnosis Procedure .....	110
<b>B1122, B1123, B1124, B1125, B1126, B1127</b>		<b>B1147 CURTAIN MODULE RH .....</b>	<b>112</b>
<b>DIAGNOSIS SENSOR UNIT .....</b>	<b>88</b>	Description .....	112
Description .....	88	DTC Logic .....	112
DTC Logic .....	88	Diagnosis Procedure .....	112
Diagnosis Procedure .....	88	<b>B1148 CURTAIN MODULE RH .....</b>	<b>114</b>
<b>B1129 SIDE MODULE RH .....</b>	<b>90</b>	Description .....	114
Description .....	90	DTC Logic .....	114
DTC Logic .....	90	Diagnosis Procedure .....	114
Diagnosis Procedure .....	90	<b>B1150 CURTAIN MODULE LH .....</b>	<b>116</b>
<b>B1130 SIDE MODULE RH .....</b>	<b>92</b>	Description .....	116
Description .....	92	DTC Logic .....	116
DTC Logic .....	92	Diagnosis Procedure .....	116
Diagnosis Procedure .....	92	<b>B1151 CURTAIN MODULE LH .....</b>	<b>118</b>
<b>B1131 SIDE MODULE RH .....</b>	<b>94</b>	Description .....	118
Description .....	94	DTC Logic .....	118
DTC Logic .....	94	Diagnosis Procedure .....	118
Diagnosis Procedure .....	94	<b>B1152 CURTAIN MODULE LH .....</b>	<b>120</b>
<b>B1132 SIDE MODULE RH .....</b>	<b>96</b>	Description .....	120
Description .....	96	DTC Logic .....	120
DTC Logic .....	96	Diagnosis Procedure .....	120
Diagnosis Procedure .....	96	<b>B1153 CURTAIN MODULE LH .....</b>	<b>122</b>
<b>B1134 SIDE MODULE LH .....</b>	<b>98</b>	Description .....	122
Description .....	98	DTC Logic .....	122
DTC Logic .....	98	Diagnosis Procedure .....	122
Diagnosis Procedure .....	98	<b>B1202, B1203, B1204, B1205, B1206, B1207</b>	
<b>B1135 SIDE MODULE LH .....</b>	<b>100</b>	<b>DIAGNOSIS SENSOR UNIT .....</b>	<b>124</b>
Description .....	100	Description .....	124
DTC Logic .....	100	DTC Logic .....	124
Diagnosis Procedure .....	100	Diagnosis Procedure .....	124
<b>B1136 SIDE MODULE LH .....</b>	<b>102</b>	<b>B1209 FRONTAL COLLISION DETECTION ..</b>	<b>126</b>
Description .....	102	Description .....	126
DTC Logic .....	102	DTC Logic .....	126
Diagnosis Procedure .....	102	Diagnosis Procedure .....	126
<b>B1137 SIDE MODULE LH .....</b>	<b>104</b>	<b>B1210 SIDE COLLISION DETECTION .....</b>	<b>128</b>
Description .....	104	Description .....	128
DTC Logic .....	104	DTC Logic .....	128
Diagnosis Procedure .....	104	Diagnosis Procedure .....	128
<b>B1138, B1139, B1140, B1141, B1142, B1143</b>		<b>ECU DIAGNOSIS INFORMATION .....</b>	<b>129</b>
<b>DIAGNOSIS SENSOR UNIT .....</b>	<b>106</b>	<b>DIAGNOSIS SENSOR UNIT .....</b>	<b>129</b>
Description .....	106	DTC Index .....	129
DTC Logic .....	106	Wiring Diagram - SRS AIR BAG CONTROL SYS-	
Diagnosis Procedure .....	106	TEM - .....	133
<b>B1145 CURTAIN MODULE RH .....</b>	<b>108</b>	<b>SYMPTOM DIAGNOSIS .....</b>	<b>140</b>
Description .....	108	<b>SRS AIR BAG WARNING LAMP DOES NOT</b>	
DTC Logic .....	108	<b>TURN OFF .....</b>	<b>140</b>
Diagnosis Procedure .....	108	Diagnosis Procedure .....	140
<b>B1146 CURTAIN MODULE RH .....</b>	<b>110</b>		

A  
B  
C  
D  
E  
F  
G  
I  
J  
K  
L  
M  
N  
O  
P

SRC

<b>SRS AIR BAG WARNING LAMP DOES NOT TURN ON</b> .....	<b>141</b>	<b>PRECAUTION</b> .....	<b>144</b>
Diagnosis Procedure .....	141	<b>PRECAUTIONS</b> .....	<b>144</b>
<b>SRS AIR BAG WARNING LAMP BLINKS</b> .....	<b>142</b>	Precaution for Supplemental Restraint System (SRS) "AIR BAG" and "SEAT BELT PRE-TEN- SIONER" .....	144
Diagnosis Procedure .....	142	Service .....	144
<b>PASSENGER SEAT BELT WARNING SYS- TEM</b> .....	<b>143</b>	Precaution for Battery Service .....	144
Diagnosis Procedure .....	143	Occupant Classification System .....	145

# DIAGNOSIS AND REPAIR WORK FLOW

< BASIC INSPECTION >

## BASIC INSPECTION

### DIAGNOSIS AND REPAIR WORK FLOW

Work Flow

INFOID:000000006450272

#### OVERALL SEQUENCE

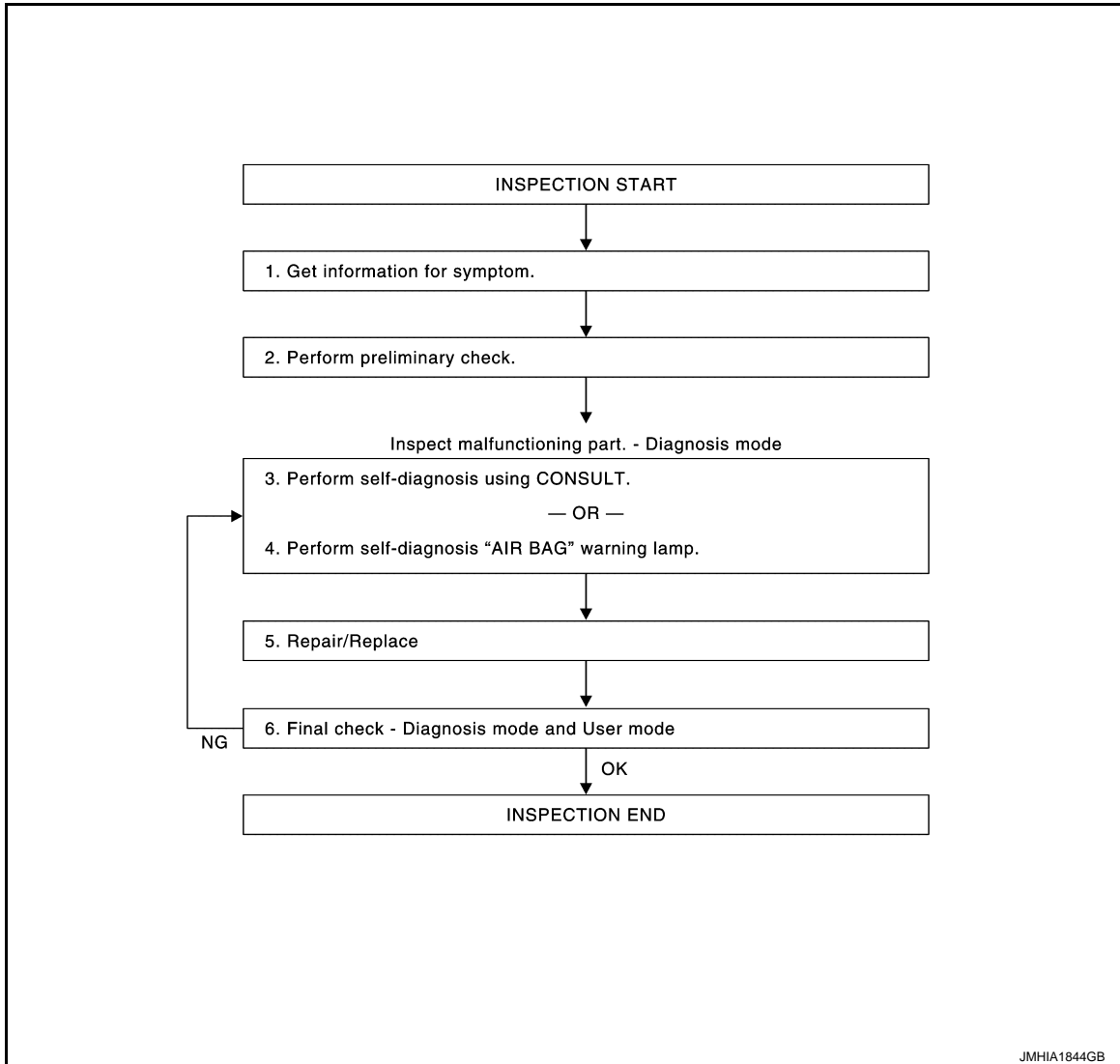

#### DETAILED FLOW

##### 1. GET INFORMATION FOR SYMPTOM

Get the detailed information from the customer about the symptom.

>> GO TO 2.

##### 2. PERFORM PRELIMINARY CHECK

At the beginning of inspection, confirm the condition of power supply circuit, check that the battery is charged and fuses and fusible links are not blown.

Is the inspection result normal?

YES-1 >> GO TO 3. (With CONSULT-III)

YES-2 >> GO TO 4. (Without CONSULT-III)

NO >> Repair or replace the battery and fuse/fusible links.

## DIAGNOSIS AND REPAIR WORK FLOW

< BASIC INSPECTION >

---

### 3.PERFORM SELF-DIAGNOSIS USING "CONSULT-III"

---

Check the screen of CONSULT-III.

Is malfunctioning part detected?

YES >> GO TO 5.

NO >> Repeat DTC confirmation with diagnostic procedure.

### 4.PERFORM SELF-DIAGNOSIS "AIR BAG" WARNING LAMP (WITHOUT CONSULT-III)

---

Check the warning lamp status.

Is malfunctioning part detected?

YES >> GO TO 5.

NO >> Repeat DTC confirmation with diagnostic procedure.

### 5.REPAIR OR REPLACE

---

Repair or replace the malfunctioning part.

After the malfunctioning is repaired, erase the self-diagnostic result. Refer to [SRC-14, "Diagnosis Description"](#).

>> GO TO 6.

### 6.FINAL CHECK

---

Check the screen of CONSULT-III and /or, Air bag warning lamp status.

Are all malfunctions corrected?

YES >> INSPECTION END

NO-1 >> GO TO 3. (With CONSULT-III)

NO-2 >> GO TO 4. (Without CONSULT-III)

# SRS AIR BAG SYSTEM

< SYSTEM DESCRIPTION >

## SYSTEM DESCRIPTION

### SRS AIR BAG SYSTEM

#### System Diagram

INFOID:000000006450273

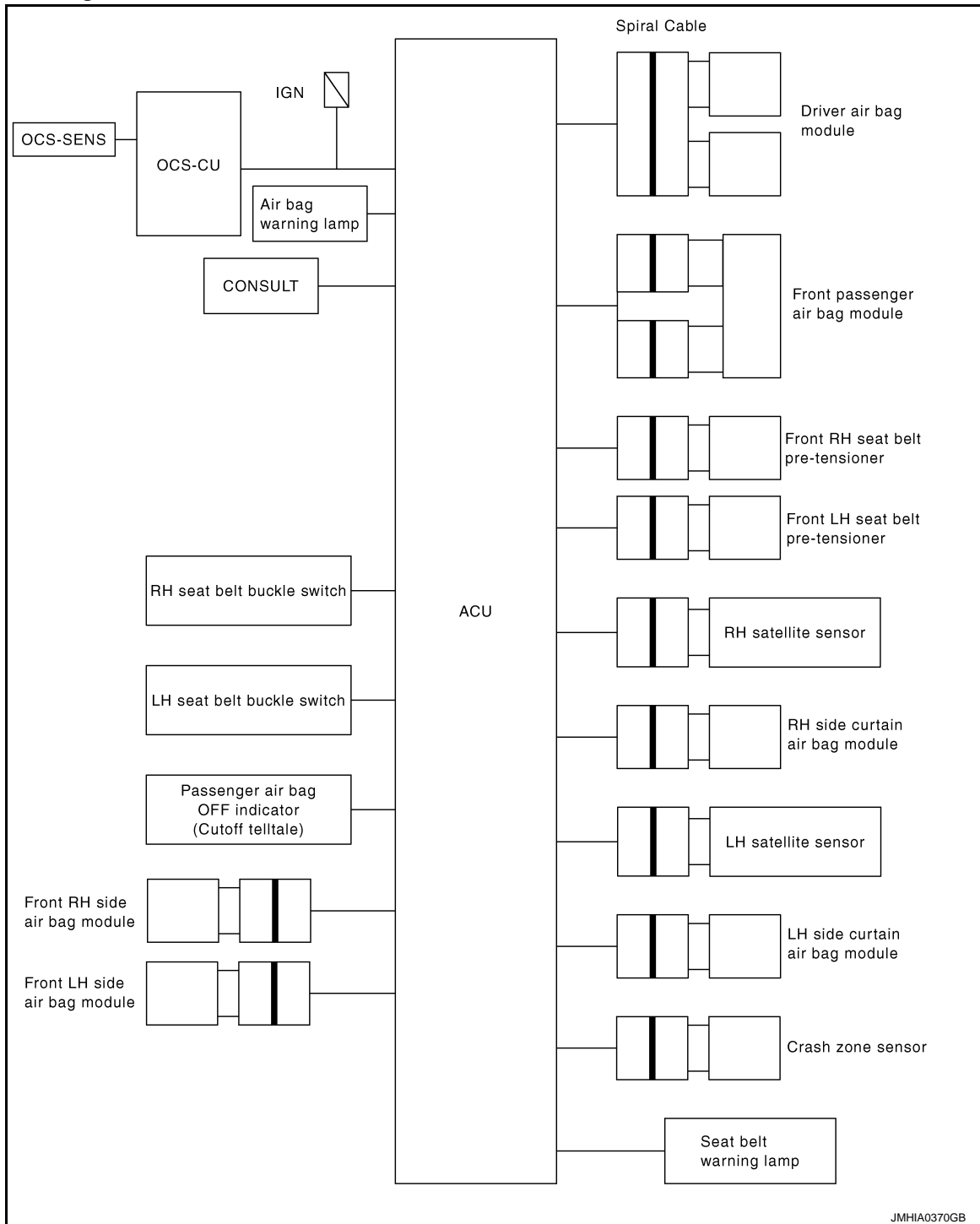

A  
B  
C  
D  
E  
F  
G  
SRC  
I  
J  
K  
L  
M  
N  
O  
P

#### System Description

INFOID:000000006450274

This SRS Air Bag System has the following functions.

- Detects a collision and supplies the energy for deploying air bag and seat belt pre-tensioner.
- Detects electrical malfunction in SRS Air Bag System and Seat Belt Pre-tensioner System, records malfunction code, and blinking air bag warning lamp.

# SRS AIR BAG SYSTEM

## < SYSTEM DESCRIPTION >

- Detects and records the deployment of air bag and seat belt pre-tensioner, and turns ON air bag warning lamp.
- Indicates malfunctioning portion with blinking times of air bag warning lamp in diagnosis mode.
- Indicates the malfunction record by CONSULT-III.
- Suppress the deployment of front passenger air bag when front passenger seat is empty or is occupied by a child or a child-seat.  
When passenger seat is occupied by a child or a child seat, turns ON front passenger air bag OFF indicator.
- When judges that passenger seat is occupied by a adult or a child and passenger seat belt is not fasten, turns ON seat belt warning lamp.

## COLLISION MODE

- The operation of supplemental restraint system is different depending on the collision modes applications. For example, the driver air bag module, front passenger air bag module and front seat belt pre-tensioner are activated in a frontal collision but not in a side collision.
- SRS configurations that are activated for some collision modes are as per the following.

×: Apply, —: Not apply

SRS configuration	Frontal collision	Left side collision	Right side collision
Driver air bag module.	×	—	—
Front passenger air bag module.	×	—	—
Front LH seat belt pre-tensioner.	×	—	—
Front RH seat belt pre-tensioner.	×	—	—
Front LH side air bag module.	—	×	—
Front RH side air bag module.	—	—	×
LH side curtain air bag module.	—	×	—
RH side curtain air bag module.	—	—	×

## Component Parts Location

INFOID:000000006450275

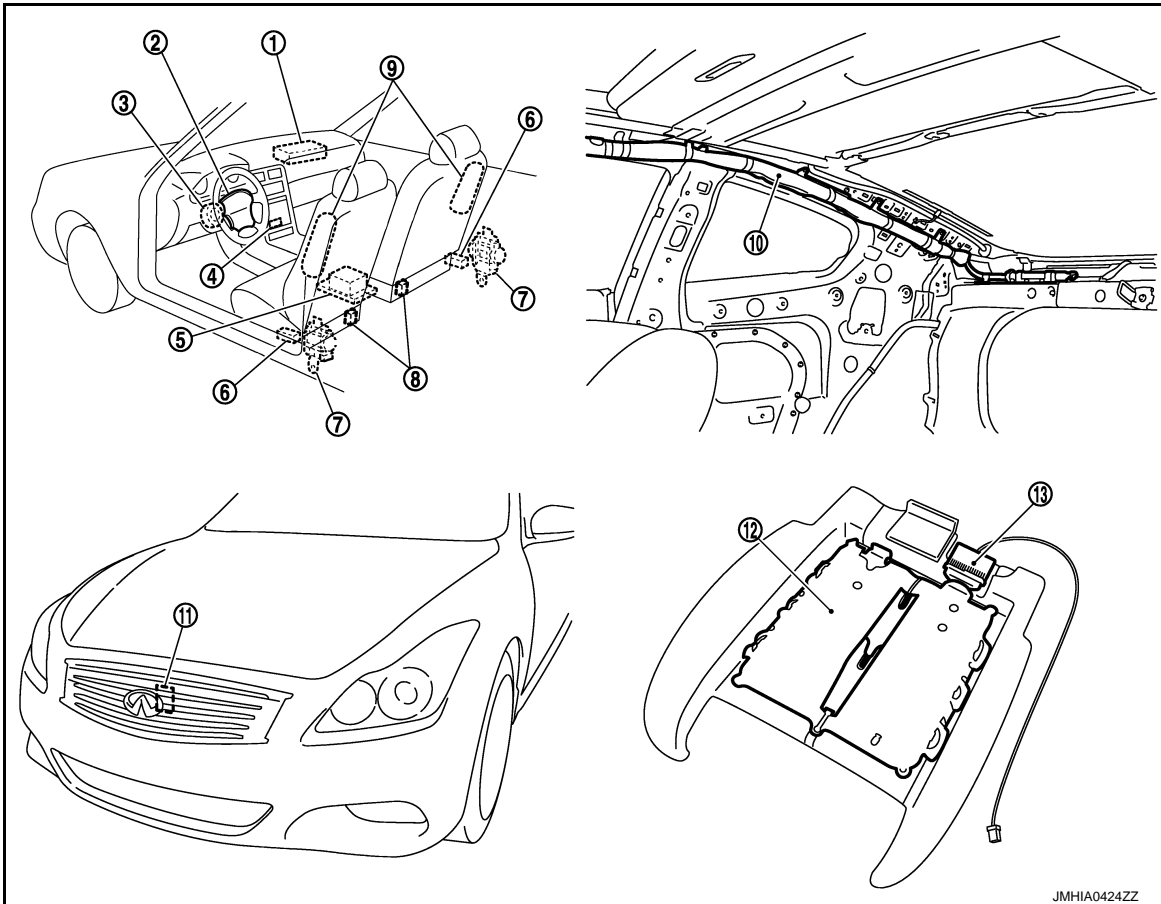

JMHIA0424ZZ



# SRS AIR BAG SYSTEM

## < SYSTEM DESCRIPTION >

- |   |                                    |                                      |
|---|------------------------------------|--------------------------------------|
| 1. Front passenger air bag module                     | 2. Driver air bag module           | 3. Spiral cable                      |
| 4. Passenger air bag off indicator (Cut-off telltale) | 5. Diagnosis sensor unit (ACU)     | 6. Satellite sensor (LH/RH)          |
| 7. Front seat belt pre-tensioner (LH/RH)              | 8. Seat belt buckle switch (LH/RH) | 9. Front side air bag module (LH/RH) |
| 10. Curtain air bag module                            | 11. Crash zone sensor              | 12. OCS seat sensor mat              |
| 13. OCS control unit                                  |                                    |                                      |

## Component Description

INFOID:000000006450276

Component	Function
Air bag diagnosis sensor unit	Detects a collision and supplies power supply for deployment to air bag module and pre-tensioner seat belt.
Air bag module <ul style="list-style-type: none"> <li>• Driver</li> <li>• Passenger</li> <li>• Front side</li> <li>• Side curtain</li> </ul>	Receives signal from air bag diagnosis sensor unit and deploys air bag.
Front seat belt pre-tensioner	Receives signal from air bag diagnosis sensor unit and deploys pre-tensioner seat belt.
Seat belt buckle switch	Controls deployment timing depending on the seat belt condition that is fastened or unfastened.
Crash zone sensor	Transmits signal to air bag diagnosis sensor unit when a frontal collision occurs.
Satellite sensor (LH/RH)	Transmits signal to air bag diagnosis sensor unit when a side collision occurs.
Occupant Classification System	Detects front passenger seat occupant and judges whether or not deploys front passenger seat air bag.
Combination meter (air bag warning lamp)	Indicates air bag malfunctioning and deployment by blinking and illuminating air bag warning lamp.
Front passenger air bag OFF indicator	Indicates whether or not front passenger air bag is in activation mode subject to the judgement by Occupant Classification System.
Combination switch (spiral cable)	Supplies power supply to driver air bag module on steering wheel.

A  
B  
C  
D  
E  
F  
G  
H  
I  
J  
K  
L  
M  
N  
O  
P

SRC

# OCCUPANT CLASSIFICATION SYSTEM

< SYSTEM DESCRIPTION >

## OCCUPANT CLASSIFICATION SYSTEM

### System Diagram

INFOID:000000006450277

### OCCUPANT CLASSIFICATION SYSTEM

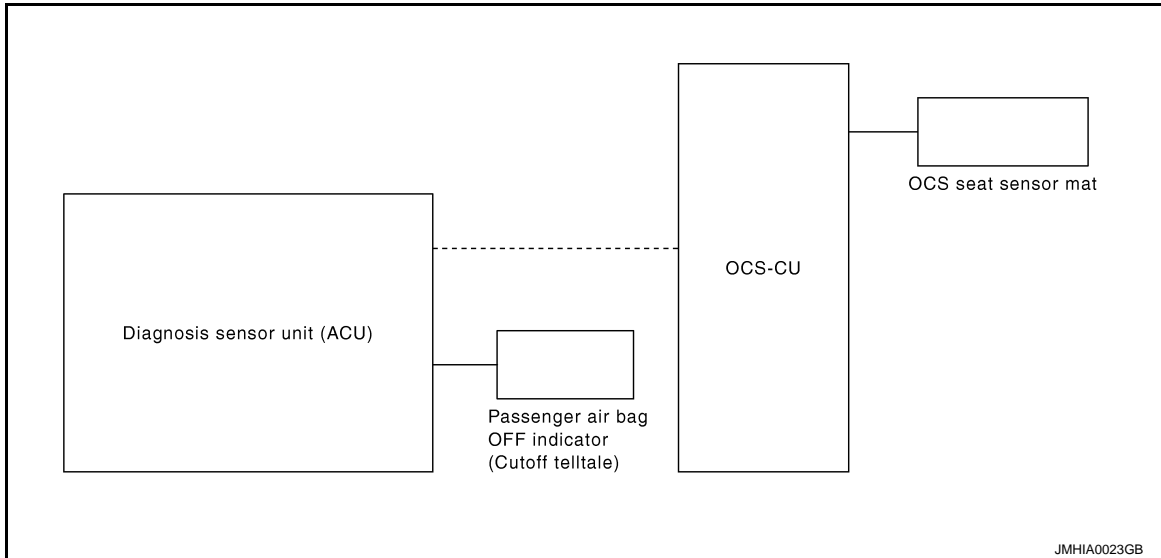

JMHIA0023GB

### System Description

INFOID:000000006450278

#### THIS OCCUPANT CLASSIFICATION SYSTEM HAS THE FOLLOWING FUNCTIONS

1. Suppress the deployment of front passenger air bag when front passenger seat is empty, or when occupied by child and child-seat. Turns ON front passenger air bag OFF indicator when front passenger seat is occupied by child-seat and child.
2. Indicates malfunction portion with blinking times of air bag warning lamp in diagnosis mode.
3. Indicates the malfunctioning record by CONSULT-III.

#### NOTE:

Operation of air bag diagnosis sensor unit when air bag diagnosis sensor unit receives information from Occupant Classification System.

Status (front passenger seat)	Passenger air bag	Front passenger air bag OFF indicator	Air bag warning lamp	Seat belt warning lamp (when front passenger seat is unbuckled)
Empty	Suppress	OFF	OFF	OFF
Child/ child-seat	Suppress	ON	OFF	ON
Adult	Enable to deploy	OFF	OFF	ON
Malfunction	Suppress	ON	Blinking	OFF

### Component Parts Location

INFOID:000000006450279

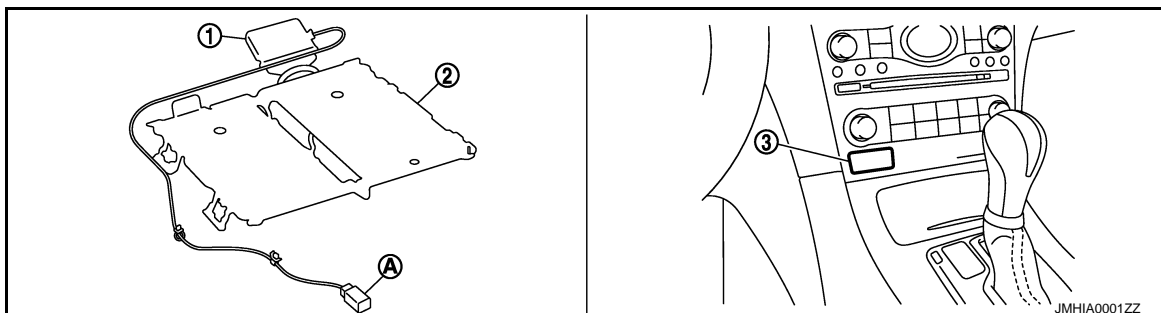

JMHIA0001ZZ

# OCCUPANT CLASSIFICATION SYSTEM

## < SYSTEM DESCRIPTION >

1. OCS control unit
  2. OCS seat sensor mat
  3. Passenger air bag OFF indicator (cut-off telltale)
- A. OCS harness connector

## Component Description

INFOID:000000006450280

Component parts	Outline of function
Seat sensor mat	Detects if the passenger seat is empty or occupied
Occupant Classification System control unit	Transmits the passenger seat status (occupied or empty) to air bag diagnosis sensor unit
Front passenger air bag OFF indicator	Turns the front passenger air bag OFF indicator lamp ON when the front passenger seat is occupied by a child or a child-seat
Air bag diagnosis sensor unit	Performs the deploy judgement of passenger air bag based on the information from Occupant Classification System control unit

A

B

C

D

E

F

G

SRC

I

J

K

L

M

N

O

P

# PASSENGER SEAT BELT WARNING SYSTEM

< SYSTEM DESCRIPTION >

## PASSENGER SEAT BELT WARNING SYSTEM

### System Diagram

INFOID:000000006450281

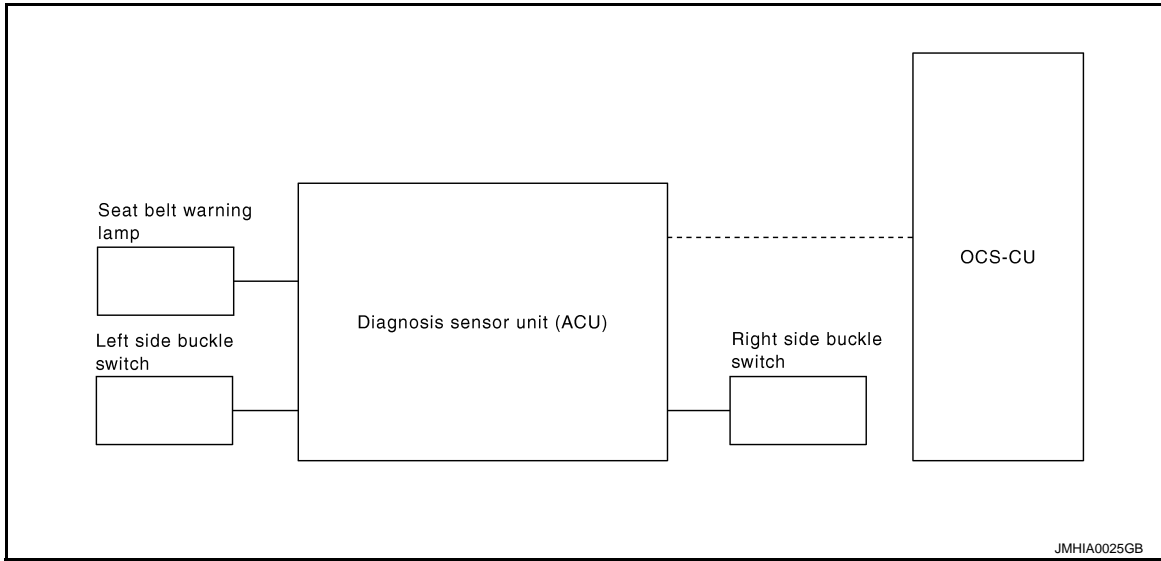

### System Description

INFOID:000000006450282

- Turns ON seat belt warning lamp, when the Occupant Classification System judges adult or child in the front passenger seat and the passenger seat belt buckle switch is OFF.
- Operation of air bag diagnosis sensor unit when air bag diagnosis sensor unit receives information from Occupant Classification System.
- In addition, seat belt warning lamp illuminates, when the driver side seat belt is not fasten. This does not relate to the air bag diagnosis sensor unit.

Status (front passenger seat)	Seat belt warning lamp (When front passenger seat is unbuckled)
Empty	OFF
Child/ child-seat	ON
Adult	ON
Malfunction	OFF

# PASSENGER SEAT BELT WARNING SYSTEM

< SYSTEM DESCRIPTION >

## Component Parts Location

INFOID:000000006450283

### SRS AIR BAG

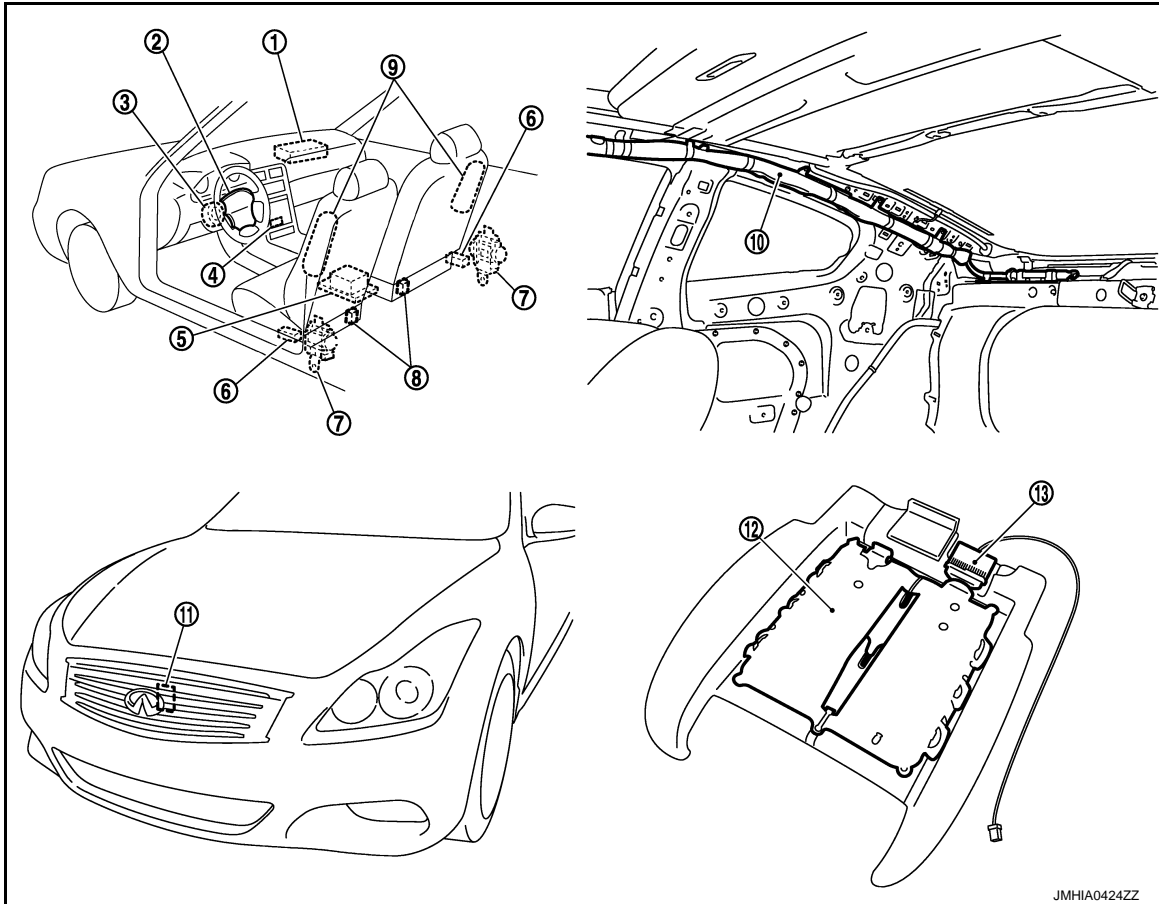

- |   |                                    |                                      |
|---|------------------------------------|--------------------------------------|
| 1. Front passenger air bag module                     | 2. Driver air bag module           | 3. Spiral cable                      |
| 4. Passenger air bag off indicator (Cut-off telltale) | 5. Diagnosis sensor unit (ACU)     | 6. Satellite sensor (LH/RH)          |
| 7. Front seat belt pre-tensioner (LH/RH)              | 8. Seat belt buckle switch (LH/RH) | 9. Front side air bag module (LH/RH) |
| 10. Curtain air bag module                            | 11. Crash zone sensor              | 12. OCS seat sensor mat              |
| 13. OCS control unit                                  |                                    |                                      |

## Component Description

INFOID:000000006450284

Component parts	Outline of function
Seat belt buckle switch (Driver side)	Detects if the seat belt buckle switch (driver side) is fastened or unfastened
Seat belt buckle switch (Passenger side)	Detects if the seat belt buckle switch (passenger side) is fastened or unfastened
Seat belt warning lamp	Turns the seat belt warning lamp ON when the seat belt is unfastened
Occupant Classification System control unit	Judges the passenger seat condition based on the information from Occupant Classification System control unit
Seat sensor mat	Detects if the passenger seat is empty or occupied
Air bag diagnosis sensor unit	Turns ON seat belt warning lamp based on the information from Occupant Classification System control unit
Front passenger air bag OFF indicator	Turns the front passenger air bag OFF indicator lamp ON when the front passenger seat is occupied by a child or a child seat

A  
B  
C  
D  
E  
F  
G  
H  
I  
J  
K  
L  
M  
N  
O  
P

SRC

# DIAGNOSIS SYSTEM (AIRBAG)

< SYSTEM DESCRIPTION >

## DIAGNOSIS SYSTEM (AIRBAG)

### Diagnosis Description

INFOID:000000006450285

#### CAUTION:

- Never use electrical test equipment on any circuit related to the SRS unless instructed in this Service Manual. SRS wiring harnesses can be identified by yellow and/or orange harnesses or harness connectors.
- Never repair, splice or modify the SRS wiring harness. If the harness is damaged, replace it with a new one.
- Keep ground portion clean.

#### DIAGNOSIS FUNCTION

- The SRS self-diagnosis results can be read by using air bag warning lamp and/or CONSULT-III.
- The user mode is exclusively prepared for the customer (driver). This mode warns the driver of a system malfunction through the operation of the air bag warning lamp.
- The diagnosis mode allows the technician to locate and inspect the malfunctioning part.
- The mode applications for the air bag warning lamp and CONSULT-III are as per the following.

	User mode	Diagnosis mode	Display type
Air bag warning lamp	X	X	ON-OFF operation
CONSULT-III	—	X	Monitoring

x: Application, —: Not application

#### HOW TO PERFORM TROUBLE DIAGNOSIS FOR QUICK AND ACCURATE REPAIR

A good understanding of the malfunction conditions can make troubleshooting faster and more accurate. In general, each customer feels differently about a malfunction. It is important to fully understand the symptoms or conditions for a customer complaint.

Information from Customer.

- WHAT..... Vehicle model.
- WHEN..... Date, Frequencies.
- WHERE..... Road conditions.
- HOW..... Operating conditions, Symptoms.

Preliminary Check.

Check that the following parts are in good order.

- Battery (Refer to [PG-3, "How to Handle Battery"](#)).
- Fuse (Refer to [PG-100, "Fuse"](#)).
- System component-to-harness connections.

#### Air Bag Warning Lamp Diagnosis

INFOID:000000006450286

#### SELF-DIAGNOSIS FUNCTION

- The reading of these results is accomplished by "User mode" and "Diagnosis mode".
- After a malfunction is repaired, turn ignition switch ON. Diagnosis mode returns to the user mode. At that time, the self-diagnosis result is cleared.

# DIAGNOSIS SYSTEM (AIRBAG)

## < SYSTEM DESCRIPTION >

### HOW TO CHANGE SELF-DIAGNOSIS MODE WITHOUT CONSULT-III

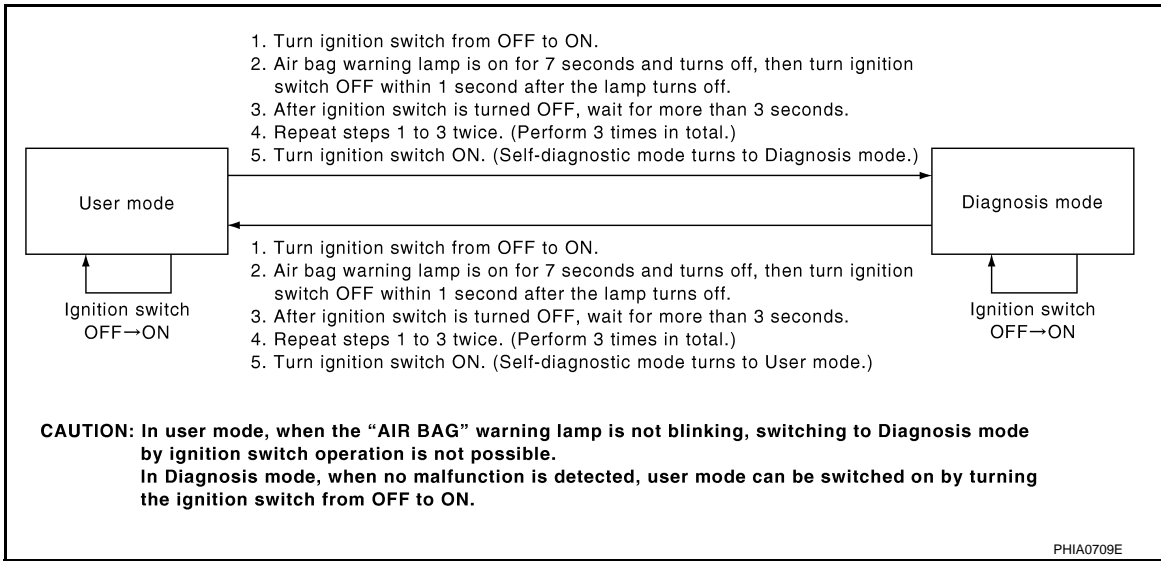

### DIAGNOSTIC PROCEDURE (USER MODE)

Checking air bag operation according to air bag warning lamp-User mode

1. Turn the ignition switch from OFF to ON, and check that the air bag warning lamp blinks.
2. Compare the air bag warning lamp blinking pattern with the examples.

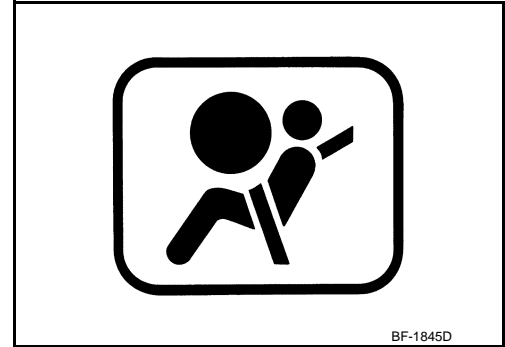

Air bag warning lamp examples (User mode)

Air bag warning lamp operation -User mode	SRS condition	Reference item
<p>SHIA0011E</p>	<ul style="list-style-type: none"> <li>• No malfunction is detected</li> <li>• No further action is necessary</li> </ul>	<p>—</p>

# DIAGNOSIS SYSTEM (AIRBAG)

## < SYSTEM DESCRIPTION >

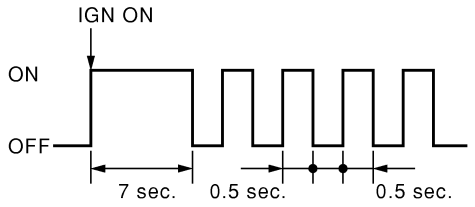
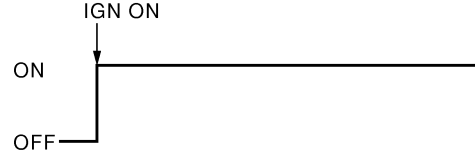
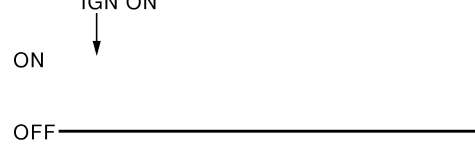
Air bag warning lamp operation -User mode	SRS condition	Reference item
 <p>SHIA0012E</p>	<p>The system is malfunctioning</p> <p>Battery voltage is low (less than 9 V)</p> <p>Intermittent malfunction has been detected in the past</p>	<p>Go to <a href="#">SRC-18, "CONSULT-III Function"</a></p> <p>Go to <a href="#">SRC-142, "Diagnosis Procedure"</a></p> <p>Go to <a href="#">GI-43, "Intermittent Incident"</a></p>
 <p>SHIA0013E</p>	<ul style="list-style-type: none"> <li>Air bag is deployed</li> <li>Seat belt pre-tensioner is deployed</li> <li>Air bag diagnosis sensor unit is malfunctioning</li> <li>Air bag power supply circuit is malfunctioning</li> <li>Air bag warning lamp circuit is malfunctioning</li> </ul>	<p>Go to <a href="#">SRC-126, "Diagnosis Procedure"</a> or <a href="#">SRC-128, "Diagnosis Procedure"</a></p> <p>Go to <a href="#">SRC-140, "Diagnosis Procedure"</a></p>
 <p>SHIA0014E</p>	<ul style="list-style-type: none"> <li>Air bag diagnosis sensor unit is malfunctioning</li> <li>Air bag warning lamp circuit is malfunctioning</li> </ul>	<p>Go to <a href="#">SRC-141, "Diagnosis Procedure"</a></p>

## DIAGNOSTIC PROCEDURE (DIAGNOSIS MODE)

- Turn the ignition switch ON, and check that the air bag warning lamp blinks.
- There are 2 blinking patterns for the air bag warning lamp. One is a 3-second blink followed by a 0.5-second blink repeated. The other is two 1.5-second blinks followed by a 0.5-second blink repeated.

An Example of a 3-second Blink Followed by a 0.5-second Blink Repeated

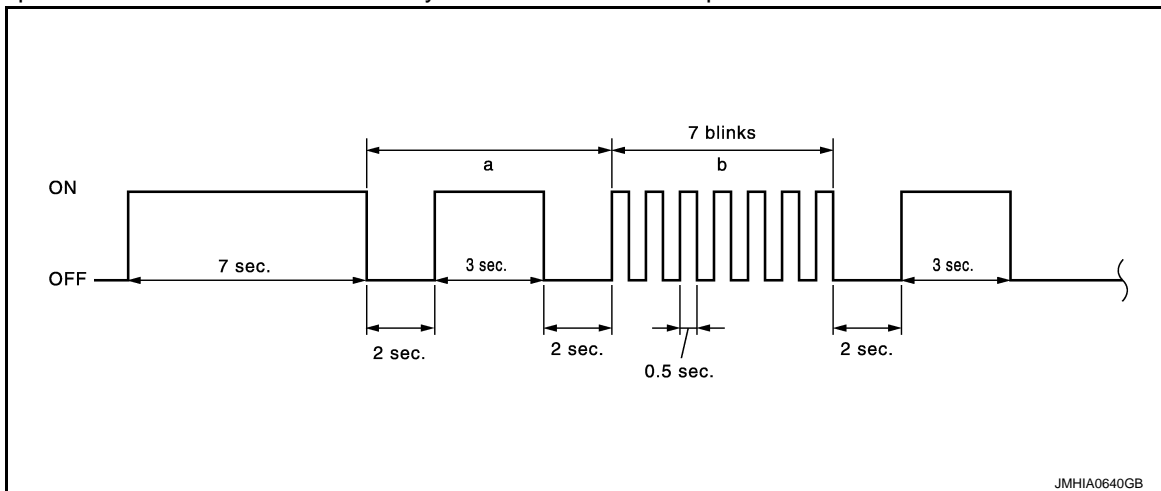

a through b are repeated.



## DIAGNOSIS SYSTEM (AIRBAG)

### < SYSTEM DESCRIPTION >

b: Seven 0.5-second blinks indicate that the air bag diagnosis sensor unit circuit is malfunctioning.

Number of 0.5-second blinks after a 3-second blink indicates malfunctioning items

Number of 0.5-second blinks	Malfunctioning items	Blinking pattern
0	Self-diagnosis result is not deleted	—
1	Front RH seat belt pre-tensioner	Refer to the following items <ul style="list-style-type: none"> <li>• <a href="#">SRC-62. "DTC Logic"</a></li> <li>• <a href="#">SRC-64. "DTC Logic"</a></li> <li>• <a href="#">SRC-66. "DTC Logic"</a></li> <li>• <a href="#">SRC-68. "DTC Logic"</a></li> </ul>
2	Driver air bag module	Refer to the following items <ul style="list-style-type: none"> <li>• <a href="#">SRC-42. "DTC Logic"</a></li> <li>• <a href="#">SRC-44. "DTC Logic"</a></li> <li>• <a href="#">SRC-46. "DTC Logic"</a></li> <li>• <a href="#">SRC-48. "DTC Logic"</a></li> </ul>
3	Front LH seat belt pre-tensioner	Refer to the following items <ul style="list-style-type: none"> <li>• <a href="#">SRC-70. "DTC Logic"</a></li> <li>• <a href="#">SRC-72. "DTC Logic"</a></li> <li>• <a href="#">SRC-74. "DTC Logic"</a></li> <li>• <a href="#">SRC-76. "DTC Logic"</a></li> </ul>
5	Occupant Classification System control unit	Refer to the following items <ul style="list-style-type: none"> <li>• <a href="#">SRC-26. "DTC Logic"</a></li> <li>• <a href="#">SRC-28. "DTC Logic"</a></li> <li>• <a href="#">SRC-30. "DTC Logic"</a></li> </ul>
6	Crash zone sensor	Refer to the following items <ul style="list-style-type: none"> <li>• <a href="#">SRC-36. "DTC Logic"</a></li> <li>• <a href="#">SRC-38. "DTC Logic"</a></li> </ul>
7	Air bag diagnosis sensor unit	Refer to the following items <ul style="list-style-type: none"> <li>• <a href="#">SRC-20. "DTC Logic"</a></li> <li>• <a href="#">SRC-22. "DTC Logic"</a></li> <li>• <a href="#">SRC-24. "DTC Logic"</a></li> <li>• <a href="#">SRC-34. "DTC Logic"</a></li> <li>• <a href="#">SRC-40. "DTC Logic"</a></li> <li>• <a href="#">SRC-50. "DTC Logic"</a></li> <li>• <a href="#">SRC-60. "DTC Logic"</a></li> <li>• <a href="#">SRC-78. "DTC Logic"</a></li> <li>• <a href="#">SRC-88. "DTC Logic"</a></li> <li>• <a href="#">SRC-106. "DTC Logic"</a></li> <li>• <a href="#">SRC-124. "DTC Logic"</a></li> </ul>
8	Front passenger air bag module	Refer to the following items <ul style="list-style-type: none"> <li>• <a href="#">SRC-52. "DTC Logic"</a></li> <li>• <a href="#">SRC-54. "DTC Logic"</a></li> <li>• <a href="#">SRC-56. "DTC Logic"</a></li> <li>• <a href="#">SRC-58. "DTC Logic"</a></li> </ul>
11	Front passenger air bag OFF indicator	Refer to <a href="#">SRC-32. "DTC Logic"</a> .

A  
B  
C  
D  
E  
F  
G  
I  
J  
K  
L  
M  
N  
O  
P

SRC

# DIAGNOSIS SYSTEM (AIRBAG)

## < SYSTEM DESCRIPTION >

An Example of Two 1.5-second Blinks Followed by a 0.5-second Blink Repeated

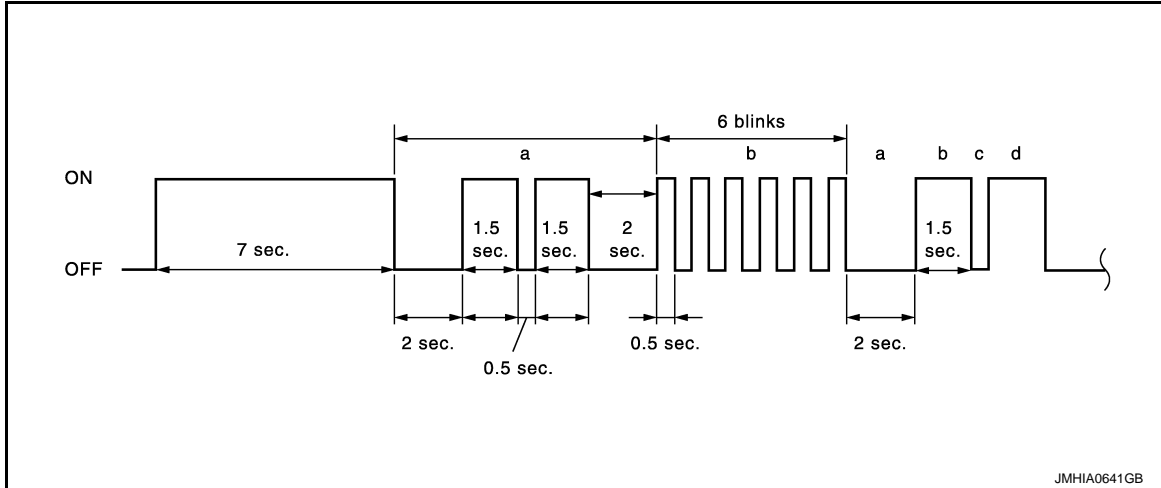

a through b are repeated.

b: Six 0.5-second blinks indicate that the LH side curtain air bag module circuit is malfunctioning.

Number of 0.5-second blinks after Two 1.5-second blinks indicates malfunctioning items

Number of 0.5-second blinks	Malfunctioning items	Blinking pattern
1	Front RH side air bag module	Refer to the following items <ul style="list-style-type: none"> <li>• <a href="#">SRC-90, "DTC Logic"</a></li> <li>• <a href="#">SRC-92, "DTC Logic"</a></li> <li>• <a href="#">SRC-94, "DTC Logic"</a></li> <li>• <a href="#">SRC-96, "DTC Logic"</a></li> </ul>
2	Front LH side air bag module	Refer to the following items <ul style="list-style-type: none"> <li>• <a href="#">SRC-98, "DTC Logic"</a></li> <li>• <a href="#">SRC-100, "DTC Logic"</a></li> <li>• <a href="#">SRC-102, "DTC Logic"</a></li> <li>• <a href="#">SRC-104, "DTC Logic"</a></li> </ul>
3	RH satellite sensor	Refer to the following items <ul style="list-style-type: none"> <li>• <a href="#">SRC-80, "DTC Logic"</a></li> <li>• <a href="#">SRC-82, "DTC Logic"</a></li> </ul>
4	LH satellite sensor	Refer to the following items <ul style="list-style-type: none"> <li>• <a href="#">SRC-84, "DTC Logic"</a></li> <li>• <a href="#">SRC-86, "DTC Logic"</a></li> </ul>
5	RH side curtain air bag module	Refer to the following items <ul style="list-style-type: none"> <li>• <a href="#">SRC-108, "DTC Logic"</a></li> <li>• <a href="#">SRC-110, "DTC Logic"</a></li> <li>• <a href="#">SRC-112, "DTC Logic"</a></li> <li>• <a href="#">SRC-114, "DTC Logic"</a></li> </ul>
6	LH side curtain air bag module	Refer to the following items <ul style="list-style-type: none"> <li>• <a href="#">SRC-116, "DTC Logic"</a></li> <li>• <a href="#">SRC-118, "DTC Logic"</a></li> <li>• <a href="#">SRC-120, "DTC Logic"</a></li> <li>• <a href="#">SRC-122, "DTC Logic"</a></li> </ul>

### HOW TO ERASE SELF-DIAGNOSTIC RESULTS

After a malfunction is repaired, turn the ignition switch OFF for at least one second, then turn ignition switch ON. Diagnosis mode returns to the user mode. At that time the self-diagnosis result is cleared.

### CONSULT-III Function

INFOID:000000006450287

### HOW TO CHANGE SELF-DIAGNOSIS MODE WITH CONSULT-III

From User Mode to Diagnosis Mode

After selecting "AIR BAG" on the "SELECT SYSTEM" screen, User mode automatically changes to Diagnosis mode.

# DIAGNOSIS SYSTEM (AIRBAG)

## < SYSTEM DESCRIPTION >

From Diagnosis Mode to User Mode

To return to User mode from Diagnosis mode, touch the "BACK" key of CONSULT-III until "SELECT SYSTEM" appears, then diagnosis mode automatically changes to User mode.

### DIAGNOSIS MODE FOR CONSULT-III

- "SELF-DIAG [CURRENT]"  
The current self-diagnosis results (also indicated with the number of air bag warning lamp blinks in diagnosis mode) are displayed on CONSULT-III screen in real time. This refers to a malfunctioning part requiring repairs.
- "SELF-DIAG [PAST]"  
Diagnosis results previously stored in the memory are displayed on CONSULT-III screen. The stored results are not erased until memory erasing is executed.
- "TROUBLE DIAG RECORD"  
With TROUBLE DIAG RECORD, diagnosis results previously erased by a reset operation can be displayed on CONSULT-III screen.
- Air bag diagnosis sensor unit ECU discriminated number (identification number) is displayed. Air bag diagnosis sensor unit has individual ECU discriminated number (identification number) based on model and equipment.

### HOW TO ERASE SELF-DIAGNOSTIC RESULTS

- "SELF-DIAG [CURRENT]"  
A current self-diagnosis result is displayed on CONSULT-III screen in real time.  
After the malfunction is repaired completely, no malfunction is detected on "SELF-DIAG [CURRENT]".
- "SELF-DIAG [PAST]"  
Return to "SELF-DIAG [CURRENT]" CONSULT-III screen by touching the "BACK" key of CONSULT-III and select "SELF-DIAG [CURRENT]" in SELECT DIAG MODE. Touch "ERASE" in "SELF-DIAG [CURRENT]" mode.

#### **NOTE:**

- If the memory of the malfunction in "SELF-DIAG [PAST]" is not erased, the user mode shows the system malfunction by the operation of the warning lamp even if the malfunction is repaired completely.
- "TROUBLE DIAG RECORD"  
The memory of "TROUBLE DIAG RECORD" cannot be erased.

A  
B  
C  
D  
E  
F  
G  
I  
J  
K  
L  
M  
N  
O  
P

SRC

# B1001, B1002, B1003, B1004, B1005 DIAGNOSIS SENSOR UNIT

< DTC/CIRCUIT DIAGNOSIS >

## DTC/CIRCUIT DIAGNOSIS

### B1001, B1002, B1003, B1004, B1005 DIAGNOSIS SENSOR UNIT

#### Description

INFOID:000000006450288

Checks the entire SRS and displays the malfunction either by illuminating or blinking the air bag warning lamp on the combination meter. Malfunctioning part can be detected by on board self-diagnosis system and CONSULT-III.

#### OPERATION

It detects a shock that exceeds a specified level and monitors whether the driver and passenger air bags, front side air bag, side curtain air bag, and pre-tensioner seat belts operate normally.

#### STRUCTURE

It contains the "G" sensors for both frontal and side collisions and spare battery function in case of main battery damage in collision.

#### INSTALLATION

Air bag diagnosis sensor unit is installed under the center console with fixed bolts.

#### DTC Logic

INFOID:000000006450289

DTC No.	Trouble diagnosis name	DTC detecting condition	Possible cause
B1001 B1002 B1003 B1004 B1005	CONTROL UNIT	Air bag diagnosis sensor unit is malfunctioning or out of the specification	<ul style="list-style-type: none"><li>Malfunction in air bag diagnosis sensor unit</li><li>Configuration in air bag diagnosis sensor unit does not match the vehicles specification</li></ul>

#### DTC CONFIRMATION PROCEDURE

##### 1. CHECK SELF-DIAG RESULT

With CONSULT-III

- Turn ignition switch ON.
- Perform "AIR BAG" Self Diagnostic Result.

Without CONSULT-III

- Turn ignition switch ON.
- Check the air bag warning lamp status. Refer to [SRC-14, "Air Bag Warning Lamp Diagnosis"](#).

#### NOTE:

SRS does not enter diagnosis mode if no malfunction is detected in user mode.

Is malfunctioning part detected?

- YES >> Refer to [SRC-20, "Diagnosis Procedure"](#).  
NO >> INSPECTION END

#### Diagnosis Procedure

INFOID:000000006450290

#### WARNING:

- Before servicing, turn ignition switch OFF, disconnect battery negative terminal and wait at least 3 minutes. (To discharge backup capacitor.)
- Never use unspecified tester or other measuring device.

##### 1. CHECK HARNESS CONNECTOR

Check the harness connector.

Is the inspection result normal?

- YES >> GO TO 2.  
NO >> Replace harness connectors.

##### 2. CHECK WIRING HARNESS

Check the wiring harness externals.

## B1001, B1002, B1003, B1004, B1005 DIAGNOSIS SENSOR UNIT

### < DTC/CIRCUIT DIAGNOSIS >

---

Is the inspection result normal?

YES >> GO TO 3.

NO >> Replace wiring harness.

### 3.REPLACE AIR BAG DIAGNOSIS SENSOR UNIT

---

1. Replace air bag diagnosis sensor unit. Refer to [SR-23, "Exploded View"](#).

2. Perform DTC confirmation procedure. Refer to [SRC-20, "DTC Logic"](#).

Is DTC detected?

YES >> GO TO 1.

NO >> INSPECTION END

A

B

C

D

E

F

G

SRC

I

J

K

L

M

N

O

P

# B1006, B1007, B1008, B1009, B1010 DIAGNOSIS SENSOR UNIT

< DTC/CIRCUIT DIAGNOSIS >

## B1006, B1007, B1008, B1009, B1010 DIAGNOSIS SENSOR UNIT

### Description

INFOID:000000006450291

Checks the entire SRS and displays the malfunction either by illuminating or blinking the air bag warning lamp on the combination meter. Malfunctioning part can be detected by on board self-diagnosis system and CONSULT-III.

### OPERATION

It detects a shock that exceeds a specified level and monitors whether the driver and passenger air bags, front side air bag, side curtain air bag and pre-tensioner seat belts operate normally.

### STRUCTURE

It contains the "G" sensors for both frontal and side collisions and spare battery function in case of main battery damage in collision.

### INSTALLATION

Air bag diagnosis sensor unit is installed under the center console with fixed bolts.

### DTC Logic

INFOID:000000006450292

DTC No.	Trouble diagnosis name	DTC detecting condition	Possible cause
B1006 B1007 B1008 B1009 B1010	CONTROL UNIT	Air bag diagnosis sensor unit is malfunctioning or out of the specification	<ul style="list-style-type: none"><li>Malfunction in air bag diagnosis sensor unit</li><li>Configuration in air bag diagnosis sensor unit does not match the vehicles specification</li></ul>

### DTC CONFIRMATION PROCEDURE

#### 1. CHECK SELF-DIAG RESULT

With CONSULT-III

- Turn ignition switch ON.
- Perform "AIR BAG" Self Diagnostic Result.

Without CONSULT-III

- Turn ignition switch ON.
- Check the air bag warning lamp status. Refer to [SRC-14, "Air Bag Warning Lamp Diagnosis"](#).

#### NOTE:

SRS does not enter diagnosis mode if no malfunction is detected in user mode.

Is malfunctioning part detected?

- YES >> Refer to [SRC-22, "Diagnosis Procedure"](#).  
NO >> INSPECTION END

### Diagnosis Procedure

INFOID:000000006450293

#### WARNING:

- Before servicing, turn ignition switch OFF, disconnect battery negative terminal and wait at least 3 minutes. (To discharge backup capacitor.)
- Never use unspecified tester or other measuring device.

#### 1. CHECK HARNESS CONNECTOR

Check the harness connector.

Is the inspection result normal?

- YES >> GO TO 2.  
NO >> Replace harness connectors.

#### 2. CHECK WIRING HARNESS

Check the wiring harness externals.

Is the inspection result normal?

- YES >> GO TO 3.

# B1006, B1007, B1008, B1009, B1010 DIAGNOSIS SENSOR UNIT

## < DTC/CIRCUIT DIAGNOSIS >

---

NO >> Replace wiring harness.

### 3. REPLACE AIR BAG DIAGNOSIS SENSOR UNIT

---

1. Replace air bag diagnosis sensor unit. Refer to [SR-23, "Exploded View"](#)
2. Perform DTC confirmation procedure. Refer to [SRC-22, "DTC Logic"](#)

#### Is DTC detected?

YES >> GO TO 1.

NO >> INSPECTION END

A  
B  
C  
D  
E  
F  
G  
I  
J  
K  
L  
M  
N  
O  
P

SRC

# B1011, B1012, B1013, B1014, B1015 DIAGNOSIS SENSOR UNIT

< DTC/CIRCUIT DIAGNOSIS >

## B1011, B1012, B1013, B1014, B1015 DIAGNOSIS SENSOR UNIT

### Description

INFOID:000000006450294

Checks the entire SRS and displays the malfunction either by illuminating or blinking the air bag warning lamp on the combination meter. Malfunctioning part can be detected by on board self-diagnosis system and CONSULT-III.

### OPERATION

It detects a shock that exceeds a specified level and monitors whether the driver and passenger air bags, front side air bag, side curtain air bag and pre-tensioner seat belts operate normally.

### STRUCTURE

It contains the "G" sensors for both frontal and side collisions and spare battery function in case of main battery damage in collision.

### INSTALLATION

Air bag diagnosis sensor unit is installed under the center console with fixed bolts.

### DTC Logic

INFOID:000000006450295

DTC No.	Trouble diagnosis name	DTC detecting condition	Possible cause
B1011 B1012 B1013 B1014 B1015	CONTROL UNIT	Air bag diagnosis sensor unit is malfunctioning or out of the specification	<ul style="list-style-type: none"><li>Malfunction in air bag diagnosis sensor unit</li><li>Configuration in air bag diagnosis sensor unit does not match the vehicles specification</li></ul>

### DTC CONFIRMATION PROCEDURE

#### 1. CHECK SELF-DIAG RESULT

With CONSULT-III

- Turn ignition switch ON.
- Perform "AIR BAG" Self Diagnostic Result.

Without CONSULT-III

- Turn ignition switch ON.
- Check the air bag warning lamp status. Refer to [SRC-14, "Air Bag Warning Lamp Diagnosis"](#).

#### NOTE:

SRS does not enter diagnosis mode if no malfunction is detected in user mode.

Is malfunctioning part detected?

- YES >> Refer to [SRC-24, "Diagnosis Procedure"](#).  
NO >> INSPECTION END

### Diagnosis Procedure

INFOID:000000006450296

#### WARNING:

- Before servicing, turn ignition switch OFF, disconnect battery negative terminal and wait at least 3 minutes. (To discharge backup capacitor.)
- Never use unspecified tester or other measuring device.

#### 1. CHECK HARNESS CONNECTOR

Check the harness connector.

Is the inspection result normal?

- YES >> GO TO 2.  
NO >> Replace harness connectors.

#### 2. CHECK WIRING HARNESS

Check the wiring harness externals.

Is the inspection result normal?

- YES >> GO TO 3.



# B1011, B1012, B1013, B1014, B1015 DIAGNOSIS SENSOR UNIT

## < DTC/CIRCUIT DIAGNOSIS >

---

NO >> Replace wiring harness.

### 3. REPLACE AIR BAG DIAGNOSIS SENSOR UNIT

---

1. Replace air bag diagnosis sensor unit. Refer to [SR-23, "Exploded View"](#)
2. Perform DTC confirmation procedure. Refer to [SRC-24, "DTC Logic"](#)

#### Is DTC detected?

YES >> GO TO 1.

NO >> INSPECTION END

A

B

C

D

E

F

G

SRC

I

J

K

L

M

N

O

P

# B1017, B1020, B1021 OCCUPANT SENS C/U

< DTC/CIRCUIT DIAGNOSIS >

## B1017, B1020, B1021 OCCUPANT SENS C/U

### Description

INFOID:000000006450297

Suppresses the deployment of front passenger air bag when the condition of passenger seat is empty or occupied with a child and child-seat. Also illuminates front passenger air bag OFF indicator lamp when the condition of passenger seat is occupied with a child-seat and child. In case of malfunction the blinking of the air bag warning lamp reports the malfunction to driver, and by the on board self-diagnosis system or CONSULT-III can detect the cause.

### OPERATION

This unit classifies occupant in passenger seat and detects electrical malfunctions in Occupant Classification System, and transmits malfunction information to air bag control unit.

### STRUCTURE

It is integrated into the seat sensor mat and detects the occupants with Occupant Classification System control unit that classifies the occupants.

### INSTALLATION

Occupant Classification System control unit is installed in the passenger seat cushion.

### DTC Logic

INFOID:000000006450298

### DTC DETECTION LOGIC

DTC No.	Trouble diagnosis name	DTC detecting condition	Possible cause
B1017 B1020 B1021	OCCUPANT SENS C/U [UNIT FAIL]	Trouble occurs in Occupant Classification System control unit	<ul style="list-style-type: none"><li>• Disconnection of wiring harness</li><li>• Malfunction in Occupant Classification System control unit</li><li>• Malfunction in air bag diagnosis sensor unit</li></ul>

### DTC CONFIRMATION PROCEDURE

#### 1. CHECK SELF-DIAG RESULT

With CONSULT-III

1. Turn ignition switch ON.
2. Perform "AIR BAG" Self Diagnostic Result CONSULT-III.

Without CONSULT-III

1. Turn ignition switch ON.
2. Check the air bag warning lamp status. Refer to [SRC-14. "Air Bag Warning Lamp Diagnosis"](#).

#### NOTE:

SRS does not enter diagnosis mode if no malfunction is detected in user mode.

Is malfunctioning part detected?

- YES >> Refer to [SRC-26. "Diagnosis Procedure"](#).  
NO >> INSPECTION END

### Diagnosis Procedure

INFOID:000000006450299

#### WARNING:

- Before servicing, turn ignition switch OFF, disconnect battery negative terminal and wait at least 3 minutes. (To discharge backup capacitor.)
- Never use unspecified tester or other measuring device.

### DIAGNOSTIC PROCEDURE

#### 1. CHECK HARNESS CONNECTOR

Check the connection of harness connector.

Is the inspection result normal?

- YES >> GO TO 2.  
NO >> Replace harness connectors.

## B1017, B1020, B1021 OCCUPANT SENS C/U

< DTC/CIRCUIT DIAGNOSIS >

---

### 2.CHECK WIRING HARNESS

---

Check the wiring harness externals.

Is the inspection result normal?

YES >> GO TO 3.

NO >> Replace wiring harness.

### 3.REPLACE AIR BAG DIAGNOSIS SENSOR UNIT

---

1. Replace air bag diagnosis sensor unit. Refer to [SR-23, "Exploded View"](#).

2. Perform DTC confirmation procedure. Refer to [SRC-26, "DTC Logic"](#).

Is DTC detected?

YES >> GO TO 4.

NO >> INSPECTION END

### 4.REPLACE OCCUPANT CLASSIFICATION SYSTEM CONTROL UNIT

---

1. Replace seat cushion frame. Refer to [SE-188, "Exploded View"](#).

2. Perform DTC confirmation procedure. Refer to [SRC-26, "DTC Logic"](#).

Is DTC detected?

YES >> GO TO 1.

NO >> INSPECTION END

A  
B  
C  
D  
E  
F  
G  
I  
J  
K  
L  
M  
N  
O  
P

SRC

# B1018 OCCUPANT SENS

< DTC/CIRCUIT DIAGNOSIS >

## B1018 OCCUPANT SENS

### Description

INFOID:000000006450300

Suppresses the deployment of front passenger air bag when the condition of passenger seat is empty or occupied with a child and child-seat. Also illuminates front passenger air bag OFF indicator lamp when the condition of passenger seat is occupied with a child-seat and child. In case of malfunction the blinking of the air bag warning lamp reports the malfunction to driver, and by the on board self-diagnosis system or CONSULT-III can detect the cause.

### OPERATION

The unit classifies occupant in passenger seat and transmits it to Occupant Classification System control unit.

### STRUCTURE

Multiple sensors are installed in the sensor mat to prevent incorrect sensing induced by the sitting position.

### INSTALLATION

Occupant Classification System sensor is installed in the passenger seat cushion.

### DTC Logic

INFOID:000000006450301

### DTC DETECTION LOGIC

DTC No.	Trouble diagnosis name	DTC detecting condition	Possible cause
B1018	OCCUPANT SENS [UNIT FAIL]	Malfunction occurs in Occupant Classification System sensor	<ul style="list-style-type: none"><li>• Disconnection of wiring harness</li><li>• Malfunction in Occupant Classification System sensor</li><li>• Malfunction in Occupant Classification System control unit</li><li>• Malfunction in air bag diagnosis sensor unit</li></ul>

### DTC CONFIRMATION PROCEDURE

#### 1. CHECK SELF-DIAG RESULT

With CONSULT-III

1. Turn ignition switch ON.
2. Perform "AIR BAG" Self Diagnostic Result CONSULT-III.

Without CONSULT-III

1. Turn ignition switch ON.
2. Check the air bag warning lamp status. Refer to [SRC-14, "Air Bag Warning Lamp Diagnosis"](#).

#### NOTE:

SRS does not enter diagnosis mode if no malfunction is detected in user mode.

Is malfunctioning part detected?

- YES >> Refer to [SRC-28, "Diagnosis Procedure"](#).  
NO >> INSPECTION END

### Diagnosis Procedure

INFOID:000000006450302

#### WARNING:

- Before servicing, turn ignition switch OFF, disconnect battery negative terminal and wait at least 3 minutes. (To discharge backup capacitor.)
- Never use unspecified tester or other measuring device.

### DIAGNOSTIC PROCEDURE

#### 1. CHECK HARNESS CONNECTOR

Check the connection of harness connector.

Is the inspection result normal?

- YES >> GO TO 2.  
NO >> Replace harness connectors.

## B1018 OCCUPANT SENS

< DTC/CIRCUIT DIAGNOSIS >

---

### 2.CHECK WIRING HARNESS

---

Check the wiring harness externals.

Is the inspection result normal?

YES >> GO TO 3.

NO >> Replace wiring harness.

### 3.REPLACE AIR BAG DIAGNOSIS SENSOR UNIT

---

1. Replace air bag diagnosis sensor unit. Refer to [SR-23, "Exploded View"](#).

2. Perform DTC confirmation procedure. Refer to [SRC-28, "DTC Logic"](#).

Is DTC detected?

YES >> GO TO 4.

NO >> INSPECTION END

### 4.REPLACE OCCUPANT CLASSIFICATION SYSTEM CONTROL UNIT AND SENSOR

---

1. Replace seat cushion frame. Refer to [SR-23, "Exploded View"](#).

2. Perform DTC confirmation procedure. Refer to [SRC-28, "DTC Logic"](#).

Is DTC detected?

YES >> GO TO 1.

NO >> INSPECTION END

A  
B  
C  
D  
E  
F  
G  
I  
J  
K  
L  
M  
N  
O  
P

SRC

# B1022 OCCUPANT SENS C/U

< DTC/CIRCUIT DIAGNOSIS >

## B1022 OCCUPANT SENS C/U

### Description

INFOID:000000006450303

Suppresses the deployment of front passenger air bag when the condition of passenger seat is empty or occupied with a child and child-seat. Also illuminates front passenger air bag OFF indicator lamp when the condition of passenger seat is occupied with a child-seat and child. In case of malfunction the blinking of the air bag warning lamp reports the malfunction to driver, and by the on board self-diagnosis system or CONSULT-III can detect the cause.

### OPERATION

This unit classifies occupant in passenger seat and detects electrical malfunction in Occupant Classification System and transmits malfunction information to air bag control unit.

### STRUCTURE

It is integrated into the seat sensor mat and detects the occupants and Occupant Classification System control unit that classifies the occupants.

### INSTALLATION

Occupant Classification System control unit is installed in the passenger seat cushion.

### DTC Logic

INFOID:000000006450304

### DTC DETECTION LOGIC

DTC No.	Trouble diagnosis name	DTC detecting condition	Possible cause
B1022	OCCUPANT SENS C/U [COMM FAIL]	Malfunction occurs in Occupant Classification System control unit, circuit of Occupant Classification System control unit-Air bag diagnosis sensor unit or Air bag diagnosis sensor unit	<ul style="list-style-type: none"><li>• Disconnection of wiring harness</li><li>• Malfunction in Occupant Classification System control unit</li><li>• Malfunction in air bag diagnosis sensor unit</li></ul>

### DTC CONFIRMATION PROCEDURE

#### 1.CHECK SELF-DIAG RESULT

With CONSULT-III

1. Turn ignition switch ON.
2. Perform "AIR BAG" Self Diagnostic Result CONSULT-III.

Without CONSULT-III

1. Turn ignition switch ON.
2. Check the air bag warning lamp status. Refer to [SRC-14. "Air Bag Warning Lamp Diagnosis"](#).

#### NOTE:

SRS does not enter diagnosis mode if no malfunction is detected in user mode.

Is malfunctioning part detected?

- YES >> Refer to [SRC-30. "Diagnosis Procedure"](#).  
NO >> INSPECTION END

### Diagnosis Procedure

INFOID:000000006450305

#### WARNING:

- Before servicing, turn ignition switch OFF, disconnect battery negative terminal and wait at least 3 minutes. (To discharge backup capacitor.)
- Never use unspecified tester or other measuring device.

### DIAGNOSTIC PROCEDURE

#### 1.CHECK HARNESS CONNECTOR

Check the connection of harness connector.

Is the inspection result normal?

- YES >> GO TO 2.  
NO >> Replace harness connectors.

## B1022 OCCUPANT SENS C/U

< DTC/CIRCUIT DIAGNOSIS >

---

### 2.CHECK WIRING HARNESS

---

Check the wiring harness externals.

Is the inspection result normal?

YES >> GO TO 3.

NO >> Replace wiring harness.

### 3.REPLACE AIR BAG DIAGNOSIS SENSOR UNIT

---

1. Replace air bag diagnosis sensor unit. Refer to [SR-23, "Exploded View"](#).

2. Perform DTC confirmation procedure. Refer to [SRC-30, "DTC Logic"](#).

Is DTC detected?

YES >> GO TO 4.

NO >> INSPECTION END

### 4.CHECK OCCUPANT CLASSIFICATION SYSTEM CONTROL UNIT

---

1. Replace seat cushion frame. Refer to [SE-188, "Exploded View"](#).

2. Perform DTC confirmation procedure. Refer to [SRC-30, "DTC Logic"](#).

Is DTC detected?

YES >> GO TO 1.

NO >> INSPECTION END

A  
B  
C  
D  
E  
F  
G  
I  
J  
K  
L  
M  
N  
O  
P

SRC

# B1023 PASS A/B INDCTR CKT

< DTC/CIRCUIT DIAGNOSIS >

## B1023 PASS A/B INDCTR CKT

### Description

INFOID:000000006450306

Suppresses the deployment of front passenger air bag when the condition of passenger seat is empty or occupied with a child and child-seat. Also illuminates front passenger air bag OFF indicator lamp when the condition of passenger seat is occupied with a child-seat and child. In case of malfunction the blinking of the air bag warning lamp reports the malfunction to driver, and by the on board self-diagnosis system or CONSULT-III can detect the cause.

### OPERATION

Illuminates front passenger air bag OFF indicator when the passenger seat is empty or occupied by a child or a child-seat.

### STRUCTURE

Front passenger air bag OFF indicator with LED illumination.

### INSTALLATION

Front passenger air bag OFF indicator is installed at the instrument panel center.

### DTC Logic

INFOID:000000006450307

### DTC DETECTION LOGIC

DTC No.	Trouble diagnosis name	DTC detecting condition	Possible cause
B1023	PASS A/B INDCTR CKT [UNIT FAIL]	Passenger air bag OFF indicator circuit is open or shorted to ground or the circuits are shorted each other	<ul style="list-style-type: none"><li>• Disconnection of wiring harness</li><li>• Malfunction in front passenger air bag OFF indicator</li><li>• Malfunction in air bag diagnosis sensor unit</li></ul>

### DTC CONFIRMATION PROCEDURE

#### 1. CHECK SELF-DIAG RESULT

With CONSULT-III

1. Turn ignition switch ON.
2. Perform "AIR BAG" Self Diagnostic Result CONSULT-III.

Without CONSULT-III

1. Turn ignition switch ON.
2. Check the air bag warning lamp status. Refer to [SRC-14, "Air Bag Warning Lamp Diagnosis"](#).

#### NOTE:

SRS does not enter diagnosis mode if no malfunction is detected in user mode.

Is malfunctioning part detected?

- YES >> Refer to [SRC-32, "Diagnosis Procedure"](#).  
NO >> INSPECTION END

### Diagnosis Procedure

INFOID:000000006450308

#### WARNING:

- Before servicing, turn ignition switch OFF, disconnect battery negative terminal and wait at least 3 minutes. (To discharge backup capacitor.)
- Never use unspecified tester or other measuring device.

### DIAGNOSTIC PROCEDURE

#### 1. CHECK HARNESS CONNECTOR

Check the connection of harness connector.

Is the inspection result normal?

- YES >> GO TO 2.  
NO >> Replace harness connectors.



## B1023 PASS A/B INDCTR CKT

< DTC/CIRCUIT DIAGNOSIS >

---

### 2.CHECK WIRING HARNESS

---

Check the wiring harness externals.

Is the inspection result normal?

YES >> GO TO 3.

NO >> Replace wiring harness.

### 3.CHECK PASSENGER AIR BAG OFF INDICATOR

---

1. Replace front passenger air bag OFF indicator. Refer to [IP-12. "A/T MODELS : Exploded View"](#) (A/T models) or [IP-23. "M/T MODELS : Exploded View"](#) (M/T models).

2. Perform DTC confirmation procedure. Refer to [SRC-32. "DTC Logic"](#).

Is DTC detected?

YES >> GO TO 4.

NO >> INSPECTION END

### 4.REPLACE AIR BAG DIAGNOSIS SENSOR UNIT

---

1. Replace air bag diagnosis sensor unit. Refer to [SR-23. "Exploded View"](#).

2. Perform DTC confirmation procedure. Refer to [SRC-32. "DTC Logic"](#).

Is DTC detected?

YES >> GO TO 1.

NO >> INSPECTION END

A  
B  
C  
D  
E  
F  
G  
I  
J  
K  
L  
M  
N  
O  
P

SRC

# B1026, B1027, B1028, B1029, B1030, B1031 DIAGNOSIS SENSOR UNIT

< DTC/CIRCUIT DIAGNOSIS >

## B1026, B1027, B1028, B1029, B1030, B1031 DIAGNOSIS SENSOR UNIT

### Description

INFOID:000000006450309

Checks the entire SRS and displays the malfunction either by illuminating or blinking the air bag warning lamp on the combination meter. Malfunctioning part can be detected by on board self-diagnosis system and CONSULT-III.

### OPERATION

It detects a shock that exceeds a specified level and monitors whether the driver and passenger air bags, front side air bag, side curtain air bag and pre-tensioner seat belts operate normally.

### STRUCTURE

It contains the "G" sensors for both frontal and side collisions and spare battery function in case of main battery damage in collision.

### INSTALLATION

Air bag diagnosis sensor unit is installed under the center console with fixed bolts.

### DTC Logic

INFOID:000000006450310

DTC No.	Trouble diagnosis name	DTC detecting condition	Possible cause
B1026 B1027 B1028 B1029 B1030 B1031	CONTROL UNIT	Air bag diagnosis sensor unit is malfunctioning or out of the specification	<ul style="list-style-type: none"><li>Malfunction in air bag diagnosis sensor unit</li><li>Configuration in air bag diagnosis sensor unit does not match the vehicle specification</li></ul>

### DTC CONFIRMATION PROCEDURE

#### 1. CHECK SELF-DIAG RESULT

With CONSULT-III

- Turn ignition switch ON.
- Perform "AIR BAG" Self Diagnostic Result.

Without CONSULT-III

- Turn ignition switch ON.
- Check the air bag warning lamp status. Refer to [SRC-14, "Air Bag Warning Lamp Diagnosis"](#).

#### NOTE:

SRS does not enter diagnosis mode if no malfunction is detected in user mode.

Is malfunctioning part detected?

YES >> Refer to [SRC-34, "Diagnosis Procedure"](#).

NO >> INSPECTION END

### Diagnosis Procedure

INFOID:000000006450311

#### WARNING:

- Before servicing, turn ignition switch OFF, disconnect battery negative terminal and wait at least 3 minutes. (To discharge backup capacitor.)
- Never use unspecified tester or other measuring device.

#### 1. CHECK HARNESS CONNECTOR

Check the harness connector.

Is the inspection result normal?

YES >> GO TO 2.

NO >> Replace harness connectors.

#### 2. CHECK WIRING HARNESS

Check the wiring harness externals.

Is the inspection result normal?

# B1026, B1027, B1028, B1029, B1030, B1031 DIAGNOSIS SENSOR UNIT

## < DTC/CIRCUIT DIAGNOSIS >

---

YES >> GO TO 3.

NO >> Replace wiring harness.

### 3. REPLACE AIR BAG DIAGNOSIS SENSOR UNIT

---

1. Replace air bag diagnosis sensor unit. Refer to [SR-23. "Exploded View"](#).

2. Perform DTC confirmation procedure. Refer to [SRC-34. "DTC Logic"](#).

#### Is DTC detected?

YES >> GO TO 1.

NO >> INSPECTION END

A

B

C

D

E

F

G

SRC

I

J

K

L

M

N

O

P

# B1033, B1034 CRASH ZONE SEN

< DTC/CIRCUIT DIAGNOSIS >

## B1033, B1034 CRASH ZONE SEN

### Description

INFOID:000000006450312

Main "G" sensor generates signal voltage, when it detects deceleration beyond the specified level caused by vehicle frontal collision.

### OPERATION

When air bag diagnosis sensor unit defines both signal voltage of the "G" sensor and the safing algorithm to be that of collision which exceeds a specified level, the driving circuit switches on and feeds the electric ignitor of both driver and passenger air bags and pre-tensioner seat belts.

### STRUCTURE

Integrated type of the "G" sensor element for frontal collision with output terminals for signal voltage.

### INSTALLATION

Crash zone sensor is installed on the radiator core support assembly with fixed nuts.

### DTC Logic

INFOID:000000006450313

DTC No.	Trouble diagnosis name	DTC detecting condition	Possible cause
B1033 B1034	CRASH ZONE SEN- SOR [UNIT FAIL]	Crash zone sensor is malfunctioning	<ul style="list-style-type: none"><li>• Disconnection of wiring harness</li><li>• Malfunction in crash zone sensor</li><li>• Malfunction in air bag diagnosis sensor unit</li></ul>

### DTC CONFIRMATION PROCEDURE

#### 1. CHECK SELF-DIAG RESULT

With CONSULT-III

1. Turn ignition switch ON.
2. Perform "AIR BAG" Self Diagnostic Result.

Without CONSULT-III

1. Turn ignition switch ON.
2. Check the air bag warning lamp status. Refer to [SRC-14. "Air Bag Warning Lamp Diagnosis"](#).

#### NOTE:

SRS does not enter diagnosis mode if no malfunction is detected in user mode.

Is malfunctioning part detected?

- YES >> Refer to [SRC-36. "Diagnosis Procedure"](#).  
NO >> INSPECTION END

### Diagnosis Procedure

INFOID:000000006450314

#### WARNING:

- Before servicing, turn ignition switch OFF, disconnect battery negative terminal and wait at least 3 minutes. (To discharge backup capacitor.)
- Never use unspecified tester or other measuring device.

#### 1. CHECK HARNESS CONNECTOR

Check the harness connector.

Is the inspection result normal?

- YES >> GO TO 2.  
NO >> Replace harness connectors.

#### 2. CHECK WIRING HARNESS

Check the wiring harness externals.

Is the inspection result normal?

- YES >> GO TO 3.  
NO >> Replace wiring harness.

## B1033, B1034 CRASH ZONE SEN

< DTC/CIRCUIT DIAGNOSIS >

---

### 3. REPLACE CRASH ZONE SENSOR

---

1. Replace crash zone sensor. Refer to [SR-21, "Exploded View"](#).
2. Perform DTC confirmation procedure. Refer to [SRC-36, "DTC Logic"](#).

Is DTC detected?

- YES >> GO TO 4.  
NO >> INSPECTION END

### 4. REPLACE AIR BAG DIAGNOSIS SENSOR UNIT

---

1. Replace air bag diagnosis sensor unit. Refer to [SR-23, "Exploded View"](#).
2. Perform DTC confirmation procedure. Refer to [SRC-36, "DTC Logic"](#).

Is DTC detected?

- YES >> GO TO 1.  
NO >> INSPECTION END

A  
B  
C  
D  
E  
F  
G  
I  
J  
K  
L  
M  
N  
O  
P

SRC

# B1035, B1036 CRASH ZONE SEN

< DTC/CIRCUIT DIAGNOSIS >

## B1035, B1036 CRASH ZONE SEN

### Description

INFOID:000000006450315

Main "G" sensor generates signal voltage, when it detects deceleration beyond the specified level caused by vehicle frontal collision.

### OPERATION

When air bag diagnosis sensor unit defines both signal voltage of the "G" sensor and the safing algorithm to be that of collision which exceeds a specified level, the driving circuit switches on and feeds the electric ignitor of both driver and passenger air bags and pre-tensioner seat belts.

### STRUCTURE

Integrated type of the "G" sensor element for frontal collision with output terminals for signal voltage.

### INSTALLATION

Crash zone sensor is installed on the radiator core support assembly with fixed nuts.

### DTC Logic

INFOID:000000006450316

DTC No.	Trouble diagnosis name	DTC detecting condition	Possible cause
B1035 B1036	CRASH ZONE SEN- SOR [COMM FAIL] [UNMATCH]	Crash zone sensor is malfunctioning or out of the specified specification	<ul style="list-style-type: none"><li>• Disconnection of wiring harness</li><li>• Malfunction in crash zone sensor</li><li>• Malfunction in air bag diagnosis sensor unit</li></ul>

### DTC CONFIRMATION PROCEDURE

#### 1.CHECK SELF-DIAG RESULT

With CONSULT-III

1. Turn ignition switch ON.
2. Perform "AIR BAG" Self Diagnostic Result.

Without CONSULT-III

1. Turn ignition switch ON.
2. Check the air bag warning lamp status. Refer to [SRC-14. "Air Bag Warning Lamp Diagnosis"](#).

#### NOTE:

SRS does not enter diagnosis mode if no malfunction is detected in user mode.

Is malfunctioning part detected?

- YES >> Refer to [SRC-38. "Diagnosis Procedure"](#).  
NO >> INSPECTION END

### Diagnosis Procedure

INFOID:000000006450317

#### WARNING:

- Before servicing, turn ignition switch OFF, disconnect battery negative terminal and wait at least 3 minutes. (To discharge backup capacitor.)
- Never use unspecified tester or other measuring device.

#### 1.CHECK HARNESS CONNECTOR

Check the harness connector.

Is the inspection result normal?

- YES >> GO TO 2.  
NO >> Replace harness connectors.

#### 2.CHECK WIRING HARNESS

Check the wiring harness externals.

Is the inspection result normal?

- YES >> GO TO 3.  
NO >> Replace wiring harness.

## B1035, B1036 CRASH ZONE SEN

< DTC/CIRCUIT DIAGNOSIS >

---

### 3.REPLACE CRASH ZONE SENSOR

---

1. Replace crash zone sensor. Refer to [SR-21, "Exploded View"](#).
2. Perform DTC confirmation procedure. Refer to [SRC-38, "DTC Logic"](#).

Is DTC detected?

- YES >> GO TO 4.  
NO >> INSPECTION END

### 4.REPLACE AIR BAG DIAGNOSIS SENSOR UNIT

---

1. Replace air bag diagnosis sensor unit. Refer to [SR-23, "Exploded View"](#).
2. Perform DTC confirmation procedure. Refer to [SRC-38, "DTC Logic"](#).

Is DTC detected?

- YES >> GO TO 1.  
NO >> INSPECTION END

A  
B  
C  
D  
E  
F  
G  
I  
J  
K  
L  
M  
N  
O  
P

SRC

# B1042, B1043, B1044, B1045, B1046, B1047 DIAGNOSIS SENSOR UNIT

< DTC/CIRCUIT DIAGNOSIS >

## B1042, B1043, B1044, B1045, B1046, B1047 DIAGNOSIS SENSOR UNIT

### Description

INFOID:000000006450318

Checks the entire SRS and displays the malfunction either by illuminating or blinking the air bag warning lamp on the combination meter. Malfunctioning part can be detected by on board self-diagnosis system and CONSULT-III.

### OPERATION

It detects a shock that exceeds a specified level and monitors whether the driver and passenger air bags, front side air bag, side curtain air bag and pre-tensioner seat belts operate normally.

### STRUCTURE

It contains the "G" sensors for both frontal and side collisions and spare battery function in case of main battery damage in collision.

### INSTALLATION

Air bag diagnosis sensor unit is installed under the center console with fixed bolts.

### DTC Logic

INFOID:000000006450319

DTC No.	Trouble diagnosis name	DTC detecting condition	Possible cause
B1042 B1043 B1044 B1045 B1046 B1047	CONTROL UNIT	Air bag diagnosis sensor unit is malfunctioning or out of the specification	<ul style="list-style-type: none"><li>Malfunction in air bag diagnosis sensor unit</li><li>Configuration in air bag diagnosis sensor unit does not match the vehicle specification</li></ul>

### DTC CONFIRMATION PROCEDURE

#### 1. CHECK SELF-DIAG RESULT

With CONSULT-III

- Turn ignition switch ON.
- Perform "AIR BAG" Self Diagnostic Result.

Without CONSULT-III

- Turn ignition switch ON.
- Check the air bag warning lamp status. Refer to [SRC-14, "Air Bag Warning Lamp Diagnosis"](#).

#### NOTE:

SRS does not enter diagnosis mode if no malfunction is detected in user mode.

Is malfunctioning part detected?

YES >> Refer to [SRC-40, "Diagnosis Procedure"](#).

NO >> INSPECTION END

### Diagnosis Procedure

INFOID:000000006450320

#### WARNING:

- Before servicing, turn ignition switch OFF, disconnect battery negative terminal and wait at least 3 minutes. (To discharge backup capacitor.)
- Never use unspecified tester or other measuring device.

#### 1. CHECK HARNESS CONNECTOR

Check the harness connector.

Is the inspection result normal?

YES >> GO TO 2.

NO >> Replace harness connectors.

#### 2. CHECK WIRING HARNESS

Check the wiring harness externals.

Is the inspection result normal?



# B1042, B1043, B1044, B1045, B1046, B1047 DIAGNOSIS SENSOR UNIT

## < DTC/CIRCUIT DIAGNOSIS >

---

YES >> GO TO 3.

NO >> Replace wiring harness.

### 3. REPLACE AIR BAG DIAGNOSIS SENSOR UNIT

---

1. Replace air bag diagnosis sensor unit. Refer to [SR-23. "Exploded View"](#).

2. Perform DTC confirmation procedure. Refer to [SRC-40. "DTC Logic"](#).

#### Is DTC detected?

YES >> GO TO 1.

NO >> INSPECTION END

A

B

C

D

E

F

G

SRC

I

J

K

L

M

N

O

P

# B1049, B1054 DRIVER AIRBAG MODULE

< DTC/CIRCUIT DIAGNOSIS >

## B1049, B1054 DRIVER AIRBAG MODULE

### Description

INFOID:000000006450321

For driver air bag module, crash is judged by main "G" sensor output signal and safing algorithm in front direction.

### OPERATION

In case of frontal collision whose acceleration exceeds the specified level, the ignition materials are ignited by electric ignition system. The system burns the gas generating materials resulting in a chemical reaction. This generates hot gases that flow into the air bag through a filter and expand the bag.

### STRUCTURE

Driver air bag module mainly consists of air bag and inflator that inflates air bag.

### INSTALLATION

Driver air bag module is installed on the center of steering wheel with fixed bolts.

### DTC Logic

INFOID:000000006450322

DTC No.	Trouble diagnosis name	DTC detecting condition	Possible cause
B1049 B1054	DRIVER AIRBAG MODULE [OPEN]	Driver air bag module circuit is open (including the spiral cable)	<ul style="list-style-type: none"><li>• Disconnection of wiring harness and open</li><li>• Malfunction in driver air bag module</li><li>• Malfunction in spiral cable</li><li>• Malfunction in air bag diagnosis sensor unit</li></ul>

### DTC CONFIRMATION PROCEDURE

#### 1. CHECK SELF-DIAG RESULT

With CONSULT-III

1. Turn ignition switch ON.
2. Perform "AIR BAG" Self Diagnostic Result.

Without CONSULT-III

1. Turn ignition switch ON.
2. Check the air bag warning lamp status. Refer to [SRC-14, "Air Bag Warning Lamp Diagnosis"](#).

#### NOTE:

SRS does not enter diagnosis mode if no malfunction is detected in user mode.

Is malfunctioning part detected?

- YES >> Refer to [SRC-42, "Diagnosis Procedure"](#).  
NO >> INSPECTION END

### Diagnosis Procedure

INFOID:000000006450323

#### WARNING:

With CONSULT-III

- Before servicing, turn ignition switch OFF, disconnect battery negative terminal and wait at least 3 minutes. (To discharge backup capacitor.)
- Never use unspecified tester or other measuring device.

#### 1. CHECK HARNESS CONNECTOR

Check the harness connector.

Is the inspection result normal?

- YES >> GO TO 2.  
NO >> Replace harness connector.

#### 2. CHECK WIRING HARNESS

Check the wiring harness externals.

Is the inspection result normal?

# B1049, B1054 DRIVER AIRBAG MODULE

## < DTC/CIRCUIT DIAGNOSIS >

- YES >> GO TO 3.  
NO >> Replace wiring harness.

### 3. CHECK SPIRAL CABLE CIRCUIT

1. Turn ignition switch OFF.
2. Disconnect driver air bag module harness connector and combination switch (spiral cable) harness connector.
3. Check continuity between driver air bag module harness connector and combination switch (spiral cable) harness connector.

Driver air bag module		Combination switch (spiral cable)		Continuity
Connector	Terminal	Connector	Terminal	
M302	10	M35	28	Existed
	11		30	
M301	12		29	
	9		30	

4. Check continuity between driver air bag module harness connector and ground.

Driver side air bag module		Ground	Continuity
Connector	Terminal		
M302	10		Not existed
	11		
M301	12		
	9		

Is the inspection result normal?

- YES >> GO TO 4.  
NO >> Replace combination switch (spiral cable). Refer to [SR-14, "Exploded View"](#).

### 4. REPLACE AIR BAG DIAGNOSIS SENSOR UNIT

1. Replace air bag diagnosis sensor unit. Refer to [SR-23, "Exploded View"](#)
2. Perform DTC confirmation procedure. Refer to [SRC-42, "DTC Logic"](#).

Is DTC detected?

- YES >> GO TO 5.  
NO >> INSPECTION END

### 5. REPLACE DRIVER AIR BAG MODULE

1. Replace driver air bag module. Refer to [SR-11, "Exploded View"](#)
2. Perform DTC confirmation procedure. Refer to [SRC-42, "DTC Logic"](#).

Is DTC detected?

- YES >> GO TO 1.  
NO >> INSPECTION END

# B1050, B1055 DRIVER AIRBAG MODULE

< DTC/CIRCUIT DIAGNOSIS >

## B1050, B1055 DRIVER AIRBAG MODULE

### Description

INFOID:000000006450324

For driver air bag module, crash is judged by main "G" sensor output signal and safing algorithm in front direction.

### OPERATION

In case of frontal collision whose acceleration exceeds the specified level, the ignition materials are ignited by electric ignition system. The system burns the gas generating materials resulting in a chemical reaction. This generates hot gases that flow into the air bag through a filter and expand the bag.

### STRUCTURE

Driver air bag module mainly consists of air bag and inflator that inflates air bag.

### INSTALLATION

Driver air bag module is installed on the center of steering wheel with fixed bolts.

### DTC Logic

INFOID:000000006450325

DTC No.	Trouble diagnosis name	DTC detecting condition	Possible cause
B1050 B1055	DRIVER AIRBAG MODULE [VB-SHORT]	Driver air bag module circuit is shorted to some power supply circuit (including the spiral cable)	<ul style="list-style-type: none"><li>• Disconnection of wiring harness and short</li><li>• Malfunction in driver air bag module</li><li>• Malfunction in spiral cable</li><li>• Malfunction in air bag diagnosis sensor unit</li></ul>

### DTC CONFIRMATION PROCEDURE

#### 1. CHECK SELF-DIAG RESULT

Ⓟ With CONSULT-III

1. Turn ignition switch ON.
2. Perform "AIR BAG" Self Diagnostic Result.

ⓧ Without CONSULT-III

1. Turn ignition switch ON.
2. Check the air bag warning lamp status. Refer to [SRC-14, "Air Bag Warning Lamp Diagnosis"](#).

#### NOTE:

SRS does not enter diagnosis mode if no malfunction is detected in user mode.

Is malfunctioning part detected?

- YES >> Refer to [SRC-44, "Diagnosis Procedure"](#).  
NO >> INSPECTION END

### Diagnosis Procedure

INFOID:000000006450326

#### WARNING:

- Before servicing, turn ignition switch OFF, disconnect battery negative terminal and wait at least 3 minutes. (To discharge backup capacitor.)
- Never use unspecified tester or other measuring device.

#### 1. CHECK HARNESS CONNECTOR

Check the harness connector.

Is the inspection result normal?

- YES >> GO TO 2.  
NO >> Replace harness connector.

#### 2. CHECK WIRING HARNESS

Check the wiring harness externals.

Is the inspection result normal?

- YES >> GO TO 3.

# B1050, B1055 DRIVER AIRBAG MODULE

## < DTC/CIRCUIT DIAGNOSIS >

NO >> Replace wiring harness.

### 3. CHECK SPIRAL CABLE CIRCUIT

1. Turn ignition switch OFF.
2. Disconnect driver air bag module harness connector and combination switch (spiral cable) harness connector.
3. Check continuity between driver air bag module harness connector and combination switch (spiral cable) harness connector.

Driver air bag module		Combination switch (spiral cable)		Continuity
Connector	Terminal	Connector	Terminal	
M302	10	M35	28	Existed
	11		30	
M301	12		29	
	9		30	

4. Check continuity between driver air bag module harness connector and ground.

Driver side air bag module		Ground	Continuity
Connector	Terminal		
M302	10		Not existed
	11		
M301	12		
	9		

Is the inspection result normal?

YES >> GO TO 4.

NO >> Replace combination switch (spiral cable). Refer to [SR-14, "Exploded View"](#).

### 4. REPLACE AIR BAG DIAGNOSIS SENSOR UNIT

1. Replace air bag diagnosis sensor unit. Refer to [SR-23, "Exploded View"](#).
2. Perform DTC confirmation procedure. Refer to [SRC-44, "DTC Logic"](#).

Is DTC detected?

YES >> GO TO 5.

NO >> INSPECTION END

### 5. REPLACE DRIVER AIR BAG MODULE

1. Replace driver air bag module. Refer to [SR-11, "Exploded View"](#).
2. Perform DTC confirmation procedure. Refer to [SRC-42, "DTC Logic"](#).

Is DTC detected?

YES >> GO TO 1.

NO >> INSPECTION END

A  
B  
C  
D  
E  
F  
G  
I  
J  
K  
L  
M  
N  
O  
P

SRC

# B1051, B1056 DRIVER AIRBAG MODULE

< DTC/CIRCUIT DIAGNOSIS >

## B1051, B1056 DRIVER AIRBAG MODULE

### Description

INFOID:000000006450327

For driver air bag module, crash is judged by main "G" sensor output signal and safing algorithm in front direction.

### OPERATION

In case of frontal collision whose acceleration exceeds the specified level, the ignition materials are ignited by electric ignition system. The system burns the gas generating materials resulting in a chemical reaction. This generates hot gases that flow into the air bag through a filter and expand the bag.

### STRUCTURE

Driver air bag module mainly consists of air bag and inflator that inflates air bag.

### INSTALLATION

Driver air bag module is installed on the center of steering wheel with fixed bolts.

### DTC Logic

INFOID:000000006450328

DTC No.	Trouble diagnosis name	DTC detecting condition	Possible cause
B1051 B1056	DRIVER AIRBAG MODULE [GND-SHORT]	Driver air bag module circuit is shorted to ground (including the spiral cable)	<ul style="list-style-type: none"><li>• Disconnection of wiring harness and short</li><li>• Malfunction in driver air bag module</li><li>• Malfunction in spiral cable</li><li>• Malfunction in air bag diagnosis sensor unit</li></ul>

### DTC CONFIRMATION PROCEDURE

#### 1. CHECK SELF-DIAG RESULT

With CONSULT-III

1. Turn ignition switch ON.
2. Perform "AIR BAG" Self Diagnostic Result.

Without CONSULT-III

1. Turn ignition switch ON.
2. Check the air bag warning lamp status. Refer to [SRC-14, "Air Bag Warning Lamp Diagnosis"](#).

#### NOTE:

SRS does not enter diagnosis mode if no malfunction is detected in user mode.

Is malfunctioning part detected?

- YES >> Refer to [SRC-46, "Diagnosis Procedure"](#).  
NO >> INSPECTION END

### Diagnosis Procedure

INFOID:000000006450329

#### WARNING:

- Before servicing, turn ignition switch OFF, disconnect battery negative terminal and wait at least 3 minutes. (To discharge backup capacitor.)
- Never use unspecified tester or other measuring device.

#### 1. CHECK HARNESS CONNECTOR

Check the harness connector.

Is the inspection result normal?

- YES >> GO TO 2.  
NO >> Replace harness connector.

#### 2. CHECK WIRING HARNESS

Check the wiring harness externals.

Is the inspection result normal?

- YES >> GO TO 3.

# B1051, B1056 DRIVER AIRBAG MODULE

## < DTC/CIRCUIT DIAGNOSIS >

NO >> Replace wiring harness.

### 3. CHECK SPIRAL CABLE CIRCUIT

1. Turn ignition switch OFF.
2. Disconnect driver air bag module harness connector and combination switch (spiral cable) harness connector.
3. Check continuity between driver air bag module harness connector and combination switch (spiral cable) harness connector.

Driver air bag module		Combination switch (spiral cable)		Continuity
Connector	Terminal	harness connector	Terminal	
M302	10	M35	28	Existed
	11		30	
M301	12		29	
	9		30	

4. Check continuity between driver air bag module harness connector and ground.

Driver side air bag module		Ground	Continuity
Connector	Terminal		
M302	10		Not existed
	11		
M301	12		
	9		

Is the inspection result normal?

YES >> GO TO 4.

NO >> Replace combination switch (spiral cable). Refer to [SR-23, "Exploded View"](#).

### 4. REPLACE AIR BAG DIAGNOSIS SENSOR UNIT

1. Replace air bag diagnosis sensor unit. Refer to [SR-23, "Exploded View"](#).
2. Perform DTC confirmation procedure. Refer to [SRC-46, "DTC Logic"](#).

Is DTC detected?

YES >> GO TO 5.

NO >> INSPECTION END

### 5. REPLACE DRIVER AIR BAG MODULE

1. Replace driver air bag module. Refer to [SR-11, "Exploded View"](#).
2. Perform DTC confirmation procedure. Refer to [SRC-46, "DTC Logic"](#).

Is DTC detected?

YES >> GO TO 1.

NO >> INSPECTION END

# B1052, B1057 DRIVER AIRBAG MODULE

< DTC/CIRCUIT DIAGNOSIS >

## B1052, B1057 DRIVER AIRBAG MODULE

### Description

INFOID:000000006450330

For driver air bag module, crash is judged by main "G" sensor output signal and safing algorithm in front direction.

### OPERATION

In case of frontal collision whose acceleration exceeds the specified level, the ignition materials are ignited by electric ignition system. The system burns the gas generating materials resulting in a chemical reaction. This generates hot gases that flow into the air bag through a filter and expand the bag.

### STRUCTURE

Driver air bag module mainly consists of air bag and inflator that inflates air bag.

### INSTALLATION

Driver air bag module is installed on the center of steering wheel with fixed bolts.

### DTC Logic

INFOID:000000006450331

DTC No.	Trouble diagnosis name	DTC detecting condition	Possible cause
B1052 B1057	DRIVER AIRBAG MODULE [SHORT]	Driver air bag module circuit are shorted to each other (including the spiral cable)	<ul style="list-style-type: none"><li>• Disconnection of wiring harness and short</li><li>• Malfunction in driver air bag module</li><li>• Malfunction in spiral cable</li><li>• Malfunction in air bag diagnosis sensor unit</li></ul>

### DTC CONFIRMATION PROCEDURE

#### 1. CHECK SELF-DIAG RESULT

With CONSULT-III

1. Turn ignition switch ON.
2. Perform "AIR BAG" Self Diagnostic Result.

Without CONSULT-III

1. Turn ignition switch ON.
2. Check the air bag warning lamp status. Refer to [SRC-14, "Air Bag Warning Lamp Diagnosis"](#).

#### NOTE:

SRS does not enter diagnosis mode if no malfunction is detected in user mode.

Is malfunctioning part detected?

- YES >> Refer to [SRC-48, "Diagnosis Procedure"](#).  
NO >> INSPECTION END

### Diagnosis Procedure

INFOID:000000006450332

#### WARNING:

- Before servicing, turn ignition switch OFF, disconnect battery negative terminal and wait at least 3 minutes. (To discharge backup capacitor.)
- Never use unspecified tester or other measuring device.

#### 1. CHECK HARNESS CONNECTOR

Check the harness connector.

Is the inspection result normal?

- YES >> GO TO 2.  
NO >> Replace harness connector.

#### 2. CHECK WIRING HARNESS

Check the wiring harness externals.

Is the inspection result normal?

- YES >> GO TO 3.



# B1052, B1057 DRIVER AIRBAG MODULE

## < DTC/CIRCUIT DIAGNOSIS >

NO >> Replace wiring harness.

### 3. CHECK SPIRAL CABLE CIRCUIT

1. Turn ignition switch OFF.
2. Disconnect driver air bag module harness connector and combination switch (spiral cable) harness connector.
3. Check continuity between driver air bag module harness connector and combination switch (spiral cable) harness connector.

Driver air bag module		Combination switch (spiral cable)		Continuity
Connector	Terminal	Connector	Terminal	
M302	10	M35	28	Existed
	11		30	
M301	12		29	
	9		30	

4. Check continuity between driver air bag module harness connector and ground.

Driver side air bag module		Ground	Continuity
Connector	Terminal		
M302	10		Not existed
	11		
M301	12		
	9		

Is the inspection result normal?

YES >> GO TO 4.

NO >> Replace combination switch (spiral cable). Refer to [SR-14, "Exploded View"](#).

### 4. REPLACE AIR BAG DIAGNOSIS SENSOR UNIT

1. Replace air bag diagnosis sensor unit. Refer to [SR-23, "Exploded View"](#).
2. Perform DTC confirmation procedure. Refer to [SRC-48, "DTC Logic"](#).

Is DTC detected?

YES >> GO TO 5.

NO >> INSPECTION END

### 5. REPLACE DRIVER AIR BAG MODULE

1. Replace driver air bag module. Refer to [SR-11, "Exploded View"](#).
2. Perform DTC confirmation procedure. Refer to [SRC-48, "DTC Logic"](#).

Is DTC detected?

YES >> GO TO 1.

NO >> INSPECTION END

A  
B  
C  
D  
E  
F  
G  
I  
J  
K  
L  
M  
N  
O  
P

SRC

# B1058, B1059, B1060, B1061, B1062, B1063 DIAGNOSIS SENSOR UNIT

< DTC/CIRCUIT DIAGNOSIS >

## B1058, B1059, B1060, B1061, B1062, B1063 DIAGNOSIS SENSOR UNIT

### Description

INFOID:000000006450333

Checks the entire SRS and displays the malfunction either by illuminating or blinking the air bag warning lamp on the combination meter. Malfunctioning part can be detected by on board self-diagnosis system and CONSULT-III.

### OPERATION

It detects a shock that exceeds a specified level and monitors whether the driver and passenger air bags, front side air bag, side curtain air bag and pre-tensioner seat belts operate normally.

### STRUCTURE

It contains the "G" sensors for both frontal and side collisions and spare battery function in case of main battery damage in collision.

### INSTALLATION

Air bag diagnosis sensor unit is installed under the center console with fixed bolts.

### DTC Logic

INFOID:000000006450334

DTC No.	Trouble diagnosis name	DTC detecting condition	Possible cause
B1058 B1059 B1060 B1061 B1062 B1063	CONTROL UNIT	Air bag diagnosis sensor unit is malfunctioning or out of the specification	<ul style="list-style-type: none"><li>Malfunction in air bag diagnosis sensor unit</li><li>Configuration in air bag diagnosis sensor unit does not match the vehicle specification</li></ul>

### DTC CONFIRMATION PROCEDURE

#### 1. CHECK SELF-DIAG RESULT

With CONSULT-III

- Turn ignition switch ON.
- Perform "AIR BAG" Self Diagnostic Result.

Without CONSULT-III

- Turn ignition switch ON.
- Check the air bag warning lamp status. Refer to [SRC-14, "Air Bag Warning Lamp Diagnosis"](#).

#### NOTE:

SRS does not enter diagnosis mode if no malfunction is detected in user mode.

Is malfunctioning part detected?

YES >> Refer to [SRC-50, "Diagnosis Procedure"](#).

NO >> INSPECTION END

### Diagnosis Procedure

INFOID:000000006450335

#### WARNING:

- Before servicing, turn ignition switch OFF, disconnect battery negative terminal and wait at least 3 minutes. (To discharge backup capacitor.)
- Never use unspecified tester or other measuring device.

#### 1. CHECK HARNESS CONNECTOR

Check the harness connector.

Is the inspection result normal?

YES >> GO TO 2.

NO >> Replace harness connectors.

#### 2. CHECK WIRING HARNESS

Check the wiring harness externals.

Is the inspection result normal?

# B1058, B1059, B1060, B1061, B1062, B1063 DIAGNOSIS SENSOR UNIT

## < DTC/CIRCUIT DIAGNOSIS >

---

YES >> GO TO 3.

NO >> Replace wiring harness.

### 3. REPLACE AIR BAG DIAGNOSIS SENSOR UNIT

---

1. Replace air bag diagnosis sensor unit. Refer to [SR-23. "Exploded View"](#).

2. Perform DTC confirmation procedure. Refer to [SRC-50. "DTC Logic"](#).

#### Is DTC detected?

YES >> GO TO 1.

NO >> INSPECTION END

A

B

C

D

E

F

G

SRC

I

J

K

L

M

N

O

P

# B1065, B1070 ASSIST A/B MODULE

< DTC/CIRCUIT DIAGNOSIS >

## B1065, B1070 ASSIST A/B MODULE

### Description

INFOID:000000006450336

For front passenger air bag module, crash is judged by main "G" sensor output signal and safing algorithm in front direction.

### OPERATION

In case of frontal collision whose acceleration exceeds the specified level, the ignition materials are ignited by electric ignition system. The system burns the gas generating materials resulting in a chemical reaction. This generates hot gases that flow into the air bag through a filter and expand the bag.

### STRUCTURE

Front passenger air bag module mainly consists of air bag and inflator that inflates air bag.

### INSTALLATION

Front passenger air bag module is installed on the instrument panel with fixed bolts.

### DTC Logic

INFOID:000000006450337

DTC No.	Trouble diagnosis name	DTC detecting condition	Possible cause
B1065 B1070	ASSIST A/B MODULE [OPEN]	Front passenger air bag module circuit is open	<ul style="list-style-type: none"><li>• Disconnection of wiring harness and open</li><li>• Malfunction in front passenger air bag module</li><li>• Malfunction in air bag diagnosis sensor unit</li></ul>

### DTC CONFIRMATION PROCEDURE

#### 1. CHECK SELF-DIAG RESULT

Ⓟ With CONSULT-III

1. Turn ignition switch ON.
2. Perform "AIR BAG" Self Diagnostic Result.

ⓧ Without CONSULT-III

1. Turn ignition switch ON.
2. Check the air bag warning lamp status. Refer to [SRC-14, "Air Bag Warning Lamp Diagnosis"](#).

#### NOTE:

SRS does not enter diagnosis mode if no malfunction is detected in user mode.

Is malfunctioning part detected?

- YES >> Refer to [SRC-52, "Diagnosis Procedure"](#).  
NO >> INSPECTION END

### Diagnosis Procedure

INFOID:000000006450338

#### WARNING:

- Before servicing, turn ignition switch OFF, disconnect battery negative terminal and wait at least 3 minutes. (To discharge backup capacitor.)
- Never use unspecified tester or other measuring device.

#### 1. CHECK HARNESS CONNECTOR

Check the harness connector.

Is the inspection result normal?

- YES >> GO TO 2.  
NO >> Replace harness connector.

#### 2. CHECK WIRING HARNESS

Check the wiring harness externals.

Is the inspection result normal?

- YES >> GO TO 3.

## B1065, B1070 ASSIST A/B MODULE

### < DTC/CIRCUIT DIAGNOSIS >

---

NO >> Replace wiring harness.

### 3.REPLACE AIR BAG DIAGNOSIS SENSOR UNIT

---

1. Replace air bag diagnosis sensor unit. Refer to [SR-23, "Exploded View"](#).
2. Perform DTC confirmation procedure. Refer to [SRC-52, "DTC Logic"](#).

#### Is DTC detected?

YES >> GO TO 4.

NO >> INSPECTION END

---

### 4.REPLACE FRONT PASSENGER AIR BAG MODULE

---

1. Replace front passenger air bag module. Refer to [SR-17, "Exploded View"](#).
2. Perform DTC confirmation procedure. Refer to [SRC-52, "DTC Logic"](#).

#### Is DTC detected?

YES >> GO TO 1.

NO >> INSPECTION END

A  
B  
C  
D  
E  
F  
G  
I  
J  
K  
L  
M  
N  
O  
P

SRC

# B1066, B1071 ASSIST A/B MODULE

< DTC/CIRCUIT DIAGNOSIS >

## B1066, B1071 ASSIST A/B MODULE

### Description

INFOID:000000006450339

For front passenger air bag module, crash is judged by main "G" sensor output signal and safing algorithm in front direction.

### OPERATION

In case of frontal collision whose acceleration exceeds the specified level, the ignition materials are ignited by electric ignition system. The system burns the gas generating materials resulting in a chemical reaction. This generates hot gases that flow into the air bag through a filter and expand the bag.

### STRUCTURE

Front passenger air bag module mainly consists of air bag and inflator that inflates air bag.

### INSTALLATION

Front passenger air bag module is installed on the instrument panel with fixed bolts.

### DTC Logic

INFOID:000000006450340

DTC No.	Trouble diagnosis name	DTC detecting condition	Possible cause
B1066 B1071	ASSIST A/B MODULE [VB-SHORT]	Front passenger air bag module circuit is shorted to some power supply circuit	<ul style="list-style-type: none"><li>• Disconnection of wiring harness and short</li><li>• Malfunction in front passenger air bag module</li><li>• Malfunction in air bag diagnosis sensor unit</li></ul>

### DTC CONFIRMATION PROCEDURE

#### 1. CHECK SELF-DIAG RESULT

Ⓟ With CONSULT-III

1. Turn ignition switch ON.
2. Perform "AIR BAG" Self Diagnostic Result.

ⓧ Without CONSULT-III

1. Turn ignition switch ON.
2. Check the air bag warning lamp status. Refer to [SRC-14, "Air Bag Warning Lamp Diagnosis"](#).

#### NOTE:

SRS does not enter diagnosis mode if no malfunction is detected in user mode.

Is malfunctioning part detected?

- YES >> Refer to [SRC-54, "Diagnosis Procedure"](#).  
NO >> INSPECTION END

### Diagnosis Procedure

INFOID:000000006450341

#### WARNING:

- Before servicing, turn ignition switch OFF, disconnect battery negative terminal and wait at least 3 minutes. (To discharge backup capacitor.)
- Never use unspecified tester or other measuring device.

#### 1. CHECK HARNESS CONNECTOR

Check the harness connector.

Is the inspection result normal?

- YES >> GO TO 2.  
NO >> Replace harness connector.

#### 2. CHECK WIRING HARNESS

Check the wiring harness externals.

Is the inspection result normal?

- YES >> GO TO 3.

## B1066, B1071 ASSIST A/B MODULE

### < DTC/CIRCUIT DIAGNOSIS >

---

NO >> Replace wiring harness.

### 3.REPLACE AIR BAG DIAGNOSIS SENSOR UNIT

---

1. Replace air bag diagnosis sensor unit. Refer to [SR-23, "Exploded View"](#).
2. Perform DTC confirmation procedure. Refer to [SRC-54, "DTC Logic"](#).

#### Is DTC detected?

YES >> GO TO 4.

NO >> INSPECTION END

### 4.REPLACE FRONT PASSENGER AIR BAG MODULE

---

1. Replace front passenger air bag module. Refer to [SR-17, "Exploded View"](#).
2. Perform DTC confirmation procedure. Refer to [SRC-54, "DTC Logic"](#).

#### Is DTC detected?

YES >> GO TO 1.

NO >> INSPECTION END

A  
B  
C  
D  
E  
F  
G  
I  
J  
K  
L  
M  
N  
O  
P

SRC

# B1067, B1072 ASSIST A/B MODULE

< DTC/CIRCUIT DIAGNOSIS >

## B1067, B1072 ASSIST A/B MODULE

### Description

INFOID:000000006450342

For front passenger air bag module, crash is judged by main "G" sensor output signal and safing algorithm in front direction.

### OPERATION

In case of frontal collision whose acceleration exceeds the specified level, the ignition materials are ignited by electric ignition system. The system burns the gas generating materials resulting in a chemical reaction. This generates hot gases that flow into the air bag through a filter and expand the bag.

### STRUCTURE

Front passenger air bag module mainly consists of air bag and inflator that inflates air bag.

### INSTALLATION

Front passenger air bag module is installed on the instrument panel with fixed bolts.

### DTC Logic

INFOID:000000006450343

DTC No.	Trouble diagnosis name	DTC detecting condition	Possible cause
B1067 B1072	ASSIST A/B MODULE [GND-SHORT]	Front passenger air bag module circuit is shorted to ground	<ul style="list-style-type: none"><li>• Disconnection of wiring harness and short</li><li>• Malfunction in front passenger air bag module</li><li>• Malfunction in air bag diagnosis sensor unit</li></ul>

### DTC CONFIRMATION PROCEDURE

#### 1. CHECK SELF-DIAG RESULT

Ⓟ With CONSULT-III

1. Turn ignition switch ON.
2. Perform "AIR BAG" Self Diagnostic Result.

ⓧ Without CONSULT-III

1. Turn ignition switch ON.
2. Check the air bag warning lamp status. Refer to [SRC-14, "Air Bag Warning Lamp Diagnosis"](#).

#### NOTE:

SRS does not enter diagnosis mode if no malfunction is detected in user mode.

Is malfunctioning part detected?

- YES >> Refer to [SRC-56, "Diagnosis Procedure"](#).  
NO >> INSPECTION END

### Diagnosis Procedure

INFOID:000000006450344

#### WARNING:

- Before servicing, turn ignition switch OFF, disconnect battery negative terminal and wait at least 3 minutes. (To discharge backup capacitor.)
- Never use unspecified tester or other measuring device.

#### 1. CHECK HARNESS CONNECTOR

Check the harness connector.

Is the inspection result normal?

- YES >> GO TO 2.  
NO >> Replace harness connector.

#### 2. CHECK WIRING HARNESS

Check the wiring harness externals.

Is the inspection result normal?

- YES >> GO TO 3.



## B1067, B1072 ASSIST A/B MODULE

### < DTC/CIRCUIT DIAGNOSIS >

---

NO >> Replace wiring harness.

### 3.REPLACE AIR BAG DIAGNOSIS SENSOR UNIT

---

1. Replace air bag diagnosis sensor unit. Refer to [SR-23, "Exploded View"](#).
2. Perform DTC confirmation procedure. Refer to [SRC-56, "DTC Logic"](#).

#### Is DTC detected?

YES >> GO TO 4.

NO >> INSPECTION END

### 4.REPLACE FRONT PASSENGER AIR BAG MODULE

---

1. Replace front passenger air bag module. Refer to [SR-17, "Exploded View"](#).
2. Perform DTC confirmation procedure. Refer to [SRC-56, "DTC Logic"](#).

#### Is DTC detected?

YES >> GO TO 1.

NO >> INSPECTION END

A  
B  
C  
D  
E  
F  
G  
I  
J  
K  
L  
M  
N  
O  
P

SRC

# B1068, B1073 ASSIST A/B MODULE

< DTC/CIRCUIT DIAGNOSIS >

## B1068, B1073 ASSIST A/B MODULE

### Description

INFOID:000000006450345

For front passenger air bag module, crash is judged by main "G" sensor output signal and safing algorithm in front direction.

### OPERATION

In case of frontal collision whose acceleration exceeds the specified level, the ignition materials are ignited by electric ignition system. The system burns the gas generating materials resulting in a chemical reaction. This generates hot gases that flow into the air bag through a filter and expand the bag.

### STRUCTURE

Front passenger air bag module mainly consists of air bag and inflator that inflates air bag.

### INSTALLATION

Front passenger air bag module is installed on the instrument panel with fixed bolts.

### DTC Logic

INFOID:000000006450346

DTC No.	Trouble diagnosis name	DTC detecting condition	Possible cause
B1068 B1073	ASSIST A/B MODULE [SHORT]	Front passenger air bag module circuits are shorted to each other	<ul style="list-style-type: none"><li>• Disconnection of wiring harness and short</li><li>• Malfunction in front passenger air bag module</li><li>• Malfunction in air bag diagnosis sensor unit</li></ul>

### DTC CONFIRMATION PROCEDURE

#### 1. CHECK SELF-DIAG RESULT

With CONSULT-III

1. Turn ignition switch ON.
2. Perform "AIR BAG" Self Diagnostic Result.

Without CONSULT-III

1. Turn ignition switch ON.
2. Check the air bag warning lamp status. Refer to [SRC-14, "Air Bag Warning Lamp Diagnosis"](#).

#### NOTE:

SRS does not enter diagnosis mode if no malfunction is detected in user mode.

Is malfunctioning part detected?

- YES >> Refer to [SRC-58, "Diagnosis Procedure"](#).  
NO >> INSPECTION END

### Diagnosis Procedure

INFOID:000000006450347

#### WARNING:

- Before servicing, turn ignition switch OFF, disconnect battery negative terminal and wait at least 3 minutes. (To discharge backup capacitor.)
- Never use unspecified tester or other measuring device.

#### 1. CHECK HARNESS CONNECTOR

Check the harness connector.

Is the inspection result normal?

- YES >> GO TO 2.  
NO >> Replace harness connector.

#### 2. CHECK WIRING HARNESS

Check the wiring harness externals.

Is the inspection result normal?

- YES >> GO TO 3.

## B1068, B1073 ASSIST A/B MODULE

### < DTC/CIRCUIT DIAGNOSIS >

---

NO >> Replace wiring harness.

#### 3. REPLACE AIR BAG DIAGNOSIS SENSOR UNIT

---

1. Replace air bag diagnosis sensor unit. Refer to [SR-23, "Exploded View"](#).
2. Perform DTC confirmation procedure. Refer to [SRC-58, "DTC Logic"](#).

##### Is DTC detected?

YES >> GO TO 4.

NO >> INSPECTION END

---

#### 4. REPLACE FRONT PASSENGER AIR BAG MODULE

---

1. Replace front passenger air bag module. Refer to [SR-17, "Exploded View"](#).
2. Perform DTC confirmation procedure. Refer to [SRC-58, "DTC Logic"](#).

##### Is DTC detected?

YES >> GO TO 1.

NO >> INSPECTION END

A  
B  
C  
D  
E  
F  
G  
I  
J  
K  
L  
M  
N  
O  
P

SRC

# B1074, B1075, B1076, B1077, B1078, B1079 DIAGNOSIS SENSOR UNIT

< DTC/CIRCUIT DIAGNOSIS >

## B1074, B1075, B1076, B1077, B1078, B1079 DIAGNOSIS SENSOR UNIT

### Description

INFOID:000000006450348

Checks the entire SRS and displays the malfunction either by illuminating or blinking the air bag warning lamp on the combination meter. Malfunctioning part can be detected by on board self-diagnosis system and CONSULT-III.

### OPERATION

It detects a shock that exceeds a specified level and monitors whether the driver and passenger air bags, front side air bag, side curtain air bag and pre-tensioner seat belts operate normally.

### STRUCTURE

It contains the "G" sensors for both frontal and side collisions and spare battery function in case of main battery damage in collision.

### INSTALLATION

Air bag diagnosis sensor unit is installed under the center console with fixed bolts.

### DTC Logic

INFOID:000000006450349

DTC No.	Trouble diagnosis name	DTC detecting condition	Possible cause
B1074 B1075 B1076 B1077 B1078 B1079	CONTROL UNIT	Air bag diagnosis sensor unit is malfunctioning or out of the specification	<ul style="list-style-type: none"><li>Malfunction in air bag diagnosis sensor unit</li><li>Configuration in air bag diagnosis sensor unit does not match the vehicle specification</li></ul>

### DTC CONFIRMATION PROCEDURE

#### 1. CHECK SELF-DIAG RESULT

④ With CONSULT-III

- Turn ignition switch ON.
- Perform "AIR BAG" Self Diagnostic Result.

④ Without CONSULT-III

- Turn ignition switch ON.
- Check the air bag warning lamp status. Refer to [SRC-14, "Air Bag Warning Lamp Diagnosis"](#).

#### NOTE:

SRS does not enter diagnosis mode if no malfunction is detected in user mode.

Is malfunctioning part detected?

YES >> Refer to [SRC-60, "Diagnosis Procedure"](#).

NO >> INSPECTION END

### Diagnosis Procedure

INFOID:000000006450350

#### WARNING:

- Before servicing, turn ignition switch OFF, disconnect battery negative terminal and wait at least 3 minutes. (To discharge backup capacitor.)
- Never use unspecified tester or other measuring device.

#### 1. CHECK HARNESS CONNECTOR

Check the harness connector.

Is the inspection result normal?

YES >> GO TO 2.

NO >> Replace harness connectors.

#### 2. CHECK WIRING HARNESS

Check the wiring harness externals.

Is the inspection result normal?

# B1074, B1075, B1076, B1077, B1078, B1079 DIAGNOSIS SENSOR UNIT

## < DTC/CIRCUIT DIAGNOSIS >

---

YES >> GO TO 3.

NO >> Replace wiring harness.

### 3. REPLACE AIR BAG DIAGNOSIS SENSOR UNIT

---

1. Replace air bag diagnosis sensor unit. Refer to [SR-23. "Exploded View"](#).

2. Perform DTC confirmation procedure. Refer to [SRC-60. "DTC Logic"](#).

#### Is DTC detected?

YES >> GO TO 1.

NO >> INSPECTION END

A

B

C

D

E

F

G

SRC

I

J

K

L

M

N

O

P

# B1081 PRE-TEN FRONT RH

< DTC/CIRCUIT DIAGNOSIS >

## B1081 PRE-TEN FRONT RH

### Description

INFOID:000000006450351

For front RH seat belt pre-tensioner, crash is judged by main "G" sensor output signal and safing algorithm in front direction.

### OPERATION

In the case of a frontal collision that exceeds specified impact level, the air bag diagnosis sensor unit detects the deceleration caused by collision. It restrains the passenger with seat belt easing the stress on passengers chest with load limiter.

### STRUCTURE

The restraint system for front seat occupant consists of the pre-tensioner mechanism and load limiter mechanism.

### INSTALLATION

Front RH seat belt pre-tensioner is installed on the underside of center pillar with fixed nuts.

### DTC Logic

INFOID:000000006450352

DTC No.	Trouble diagnosis name	DTC detecting condition	Possible cause
B1081	PRE-TEN FRONT RH [OPEN]	Front RH seat belt pre-tensioner circuit is open	<ul style="list-style-type: none"><li>• Disconnection of wiring harness and open</li><li>• Malfunction in front RH seat belt pre-tensioner</li><li>• Malfunction in air bag diagnosis sensor unit</li></ul>

### DTC CONFIRMATION PROCEDURE

#### 1.CHECK SELF-DIAG RESULT

With CONSULT-III

1. Turn ignition switch ON.
2. Perform "AIR BAG" Self Diagnostic Result.

Without CONSULT-III

1. Turn ignition switch ON.
2. Check the air bag warning lamp status. Refer to [SRC-14, "Air Bag Warning Lamp Diagnosis"](#).

#### NOTE:

SRS does not enter diagnosis mode if no malfunction is detected in user mode.

Is malfunctioning part detected?

YES >> Refer to [SRC-62, "Diagnosis Procedure"](#).

NO >> INSPECTION END

### Diagnosis Procedure

INFOID:000000006450353

#### WARNING:

- Before servicing, turn ignition switch OFF, disconnect battery negative terminal and wait at least 3 minutes. (To discharge backup capacitor.)
- Never use unspecified tester or other measuring device.

#### 1.CHECK HARNESS CONNECTOR

Check the harness connector.

Is the inspection result normal?

YES >> GO TO 2.

NO >> Replace harness connector.

#### 2.CHECK WIRING HARNESS

Check the wiring harness externals.

Is the inspection result normal?

## B1081 PRE-TEN FRONT RH

### < DTC/CIRCUIT DIAGNOSIS >

---

- YES >> GO TO 3.  
NO >> Replace wiring harness.

### 3.REPLACE FRONT SEAT BELT PRE-TENSIONER

---

1. Replace front RH seat belt pre-tensioner. Refer to [SB-6. "SEAT BELT RETRACTOR : Exploded View"](#).
2. Perform DTC confirmation procedure. Refer to [SRC-62. "DTC Logic"](#).

#### Is DTC detected?

- YES >> GO TO 4.  
NO >> INSPECTION END

### 4.REPLACE AIR BAG DIAGNOSIS SENSOR UNIT

---

1. Replace air bag diagnosis sensor unit. Refer to [SR-23. "Exploded View"](#).
2. Perform DTC confirmation procedure. Refer to [SRC-62. "DTC Logic"](#).

#### Is DTC detected?

- YES >> GO TO 1.  
NO >> INSPECTION END

A  
B  
C  
D  
E  
F  
G  
I  
J  
K  
L  
M  
N  
O  
P

SRC

# B1082 PRE-TEN FRONT RH

< DTC/CIRCUIT DIAGNOSIS >

## B1082 PRE-TEN FRONT RH

### Description

INFOID:000000006450354

For front RH seat belt pre-tensioner, crash is judged by main "G" sensor output signal and safing algorithm in front direction.

### OPERATION

In the case of a frontal collision that exceeds specified impact level, the air bag diagnosis sensor unit detects the deceleration caused by collision. It restrains the passenger with seat belt easing the stress on passengers chest with load limiter.

### STRUCTURE

The restraint system for front seat occupant consists of the pre-tensioner mechanism and load limiter mechanism.

### INSTALLATION

Front RH seat belt pre-tensioner is installed on the underside of center pillar with fixed nuts.

### DTC Logic

INFOID:000000006450355

DTC No.	Trouble diagnosis name	DTC detecting condition	Possible cause
B1082	PRE-TEN FRONT RH [VB-SHORT]	Front RH seat belt pre-tensioner circuit is shorted to some power supply circuit	<ul style="list-style-type: none"><li>• Disconnection of wiring harness and short</li><li>• Malfunction in front RH seat belt pre-tensioner</li><li>• Malfunction in air bag diagnosis sensor unit</li></ul>

### DTC CONFIRMATION PROCEDURE

#### 1. CHECK SELF-DIAG RESULT

With CONSULT-III

1. Turn ignition switch ON.
2. Perform "AIR BAG" Self Diagnostic Result.

Without CONSULT-III

1. Turn ignition switch ON.
2. Check the air bag warning lamp status. Refer to [SRC-14, "Air Bag Warning Lamp Diagnosis"](#).

#### NOTE:

SRS does not enter diagnosis mode if no malfunction is detected in user mode.

Is malfunctioning part detected?

YES >> Refer to [SRC-64, "Diagnosis Procedure"](#).

NO >> INSPECTION END

### Diagnosis Procedure

INFOID:000000006450356

#### WARNING:

- Before servicing, turn ignition switch OFF, disconnect battery negative terminal and wait at least 3 minutes. (To discharge backup capacitor.)
- Never use unspecified tester or other measuring device.

#### 1. CHECK HARNESS CONNECTOR

Check the harness connector.

Is the inspection result normal?

YES >> GO TO 2.

NO >> Replace harness connector.

#### 2. CHECK WIRING HARNESS

Check the wiring harness externals.

Is the inspection result normal?



## B1082 PRE-TEN FRONT RH

### < DTC/CIRCUIT DIAGNOSIS >

---

YES >> GO TO 3.

NO >> Replace wiring harness.

### 3.REPLACE FRONT SEAT BELT PRE-TENSIONER

---

1. Replace front RH seat belt pre-tensioner. Refer to [SB-6. "SEAT BELT RETRACTOR : Exploded View"](#).

2. Perform DTC confirmation procedure. Refer to [SRC-64. "DTC Logic"](#).

#### Is DTC detected?

YES >> GO TO 4.

NO >> INSPECTION END

### 4.REPLACE AIR BAG DIAGNOSIS SENSOR UNIT

---

1. Replace air bag diagnosis sensor unit. Refer to [SR-23. "Exploded View"](#).

2. Perform DTC confirmation procedure. Refer to [SRC-64. "DTC Logic"](#).

#### Is DTC detected?

YES >> GO TO 1.

NO >> INSPECTION END

A  
B  
C  
D  
E  
F  
G  
I  
J  
K  
L  
M  
N  
O  
P

SRC

# B1083 PRE-TEN FRONT RH

< DTC/CIRCUIT DIAGNOSIS >

## B1083 PRE-TEN FRONT RH

### Description

INFOID:000000006450357

For front RH seat belt pre-tensioner, crash is judged by main "G" sensor output signal and safing algorithm in front direction.

### OPERATION

In the case of a frontal collision that exceeds specified impact level, the air bag diagnosis sensor unit detects the deceleration caused by collision. It restrains the passenger with seat belt easing the stress on passengers chest with load limiter.

### STRUCTURE

The restraint system for front seat occupant consists of the pre-tensioner mechanism and load limiter mechanism.

### INSTALLATION

Front RH seat belt pre-tensioner is installed on the underside of center pillar with fixed nuts.

### DTC Logic

INFOID:000000006450358

DTC No.	Trouble diagnosis name	DTC detecting condition	Possible cause
B1083	PRE-TEN FRONT RH [GND-SHORT]	Front RH seat belt pre-tensioner circuit is shorted to ground	<ul style="list-style-type: none"><li>• Disconnection of wiring harness and short</li><li>• Malfunction in front RH seat belt pre-tensioner</li><li>• Malfunction in air bag diagnosis sensor unit</li></ul>

### DTC CONFIRMATION PROCEDURE

#### 1. CHECK SELF-DIAG RESULT

With CONSULT-III

1. Turn ignition switch ON.
2. Perform "AIR BAG" Self Diagnostic Result.

Without CONSULT-III

1. Turn ignition switch ON.
2. Check the air bag warning lamp status. Refer to [SRC-14, "Air Bag Warning Lamp Diagnosis"](#).

#### NOTE:

SRS does not enter diagnosis mode if no malfunction is detected in user mode.

Is malfunctioning part detected?

- YES >> Refer to [SRC-66, "Diagnosis Procedure"](#).  
NO >> INSPECTION END

### Diagnosis Procedure

INFOID:000000006450359

#### WARNING:

- Before servicing, turn ignition switch OFF, disconnect battery negative terminal and wait at least 3 minutes. (To discharge backup capacitor.)
- Never use unspecified tester or other measuring device.

#### 1. CHECK HARNESS CONNECTOR

Check the harness connector.

Is the inspection result normal?

- YES >> GO TO 2.  
NO >> Replace harness connector.

#### 2. CHECK WIRING HARNESS

Check the wiring harness externals.

Is the inspection result normal?

## B1083 PRE-TEN FRONT RH

### < DTC/CIRCUIT DIAGNOSIS >

---

YES >> GO TO 3.

NO >> Replace wiring harness.

### 3.REPLACE FRONT SEAT BELT PRE-TENSIONER

---

1. Replace front RH seat belt pre-tensioner. Refer to [SB-6. "SEAT BELT RETRACTOR : Exploded View"](#).

2. Perform DTC confirmation procedure. Refer to [SRC-66. "DTC Logic"](#).

#### Is DTC detected?

YES >> GO TO 4.

NO >> INSPECTION END

### 4.REPLACE AIR BAG DIAGNOSIS SENSOR UNIT

---

1. Replace air bag diagnosis sensor unit. Refer to [SR-23. "Exploded View"](#).

2. Perform DTC confirmation procedure. Refer to [SRC-66. "DTC Logic"](#).

#### Is DTC detected?

YES >> GO TO 1.

NO >> INSPECTION END

A  
B  
C  
D  
E  
F  
G  
I  
J  
K  
L  
M  
N  
O  
P

SRC

# B1084 PRE-TEN FRONT RH

< DTC/CIRCUIT DIAGNOSIS >

## B1084 PRE-TEN FRONT RH

### Description

INFOID:000000006450360

For front RH seat belt pre-tensioner, crash is judged by main "G" sensor output signal and safing algorithm in front direction.

### OPERATION

In the case of a frontal collision that exceeds specified impact level, the air bag diagnosis sensor unit detects the deceleration caused by collision. It restrains the passenger with seat belt easing the stress on passengers chest with load limiter.

### STRUCTURE

The restraint system for front seat occupant consists of the pre-tensioner mechanism and load limiter mechanism.

### INSTALLATION

Front RH seat belt pre-tensioner is installed on the underside of center pillar with fixed nuts.

### DTC Logic

INFOID:000000006450361

DTC No.	Trouble diagnosis name	DTC detecting condition	Possible cause
B1084	PRE-TEN FRONT RH [SHORT]	Front RH seat belt pre-tensioner circuit are shorted to each other	<ul style="list-style-type: none"><li>• Disconnection of wiring harness and short</li><li>• Malfunction in front RH seat belt pre-tensioner</li><li>• Malfunction in air bag diagnosis sensor unit</li></ul>

### DTC CONFIRMATION PROCEDURE

#### 1. CHECK SELF-DIAG RESULT

With CONSULT-III

1. Turn ignition switch ON.
2. Perform "AIR BAG" Self Diagnostic Result.

Without CONSULT-III

1. Turn ignition switch ON.
2. Check the air bag warning lamp status. Refer to [SRC-14, "Air Bag Warning Lamp Diagnosis"](#).

#### NOTE:

SRS does not enter diagnosis mode if no malfunction is detected in user mode.

Is malfunctioning part detected?

- YES >> Refer to [SRC-68, "Diagnosis Procedure"](#).  
NO >> INSPECTION END

### Diagnosis Procedure

INFOID:000000006450362

#### WARNING:

- Before servicing, turn ignition switch OFF, disconnect battery negative terminal and wait at least 3 minutes. (To discharge backup capacitor.)
- Never use unspecified tester or other measuring device.

#### 1. CHECK HARNESS CONNECTOR

Check the harness connector.

Is the inspection result normal?

- YES >> GO TO 2.  
NO >> Replace harness connector.

#### 2. CHECK WIRING HARNESS

Check the wiring harness externals.

Is the inspection result normal?

# B1084 PRE-TEN FRONT RH

## < DTC/CIRCUIT DIAGNOSIS >

---

- YES >> GO TO 3.
- NO >> Replace wiring harness.

### 3.REPLACE FRONT SEAT BELT PRE-TENSIONER

---

1. Replace front RH seat belt pre-tensioner. Refer to [SB-6. "SEAT BELT RETRACTOR : Exploded View"](#).
2. Perform DTC confirmation procedure. Refer to [SRC-68. "DTC Logic"](#).

#### Is DTC detected?

- YES >> GO TO 4.
- NO >> INSPECTION END

### 4.REPLACE AIR BAG DIAGNOSIS SENSOR UNIT

---

1. Replace air bag diagnosis sensor unit. Refer to [SR-23. "Exploded View"](#).
2. Perform DTC confirmation procedure. Refer to [SRC-68. "DTC Logic"](#).

#### Is DTC detected?

- YES >> GO TO 1.
- NO >> INSPECTION END

A  
B  
C  
D  
E  
F  
G  
I  
J  
K  
L  
M  
N  
O  
P

SRC

# B1086 PRE-TEN FRONT LH

< DTC/CIRCUIT DIAGNOSIS >

## B1086 PRE-TEN FRONT LH

### Description

INFOID:000000006450363

For front LH seat belt pre-tensioner, crash is judged by main "G" sensor output signal and safing algorithm in front direction.

### OPERATION

In the case of a frontal collision that exceeds specified impact level, the air bag diagnosis sensor unit detects the deceleration caused by collision. It restrains the passenger with seat belt easing the stress on passengers chest with load limiter.

### STRUCTURE

The restraint system for front seat occupant consists of the pre-tensioner mechanism and load limiter mechanism.

### INSTALLATION

Front LH seat belt pre-tensioner is installed on the underside of center pillar with fixed nuts.

### DTC Logic

INFOID:000000006450364

DTC No.	Trouble diagnosis name	DTC detecting condition	Possible cause
B1086	PRE-TEN FRONT LH [OPEN]	Front LH seat belt pre-tensioner circuit is open	<ul style="list-style-type: none"><li>• Disconnection of wiring harness and open</li><li>• Malfunction in front LH seat belt pre-tensioner</li><li>• Malfunction in air bag diagnosis sensor unit</li></ul>

### DTC CONFIRMATION PROCEDURE

#### 1. CHECK SELF-DIAG RESULT

With CONSULT-III

1. Turn ignition switch ON.
2. Perform "AIR BAG" Self Diagnostic Result.

Without CONSULT-III

1. Turn ignition switch ON.
2. Check the air bag warning lamp status. Refer to [SRC-14, "Air Bag Warning Lamp Diagnosis"](#).

#### NOTE:

SRS does not enter diagnosis mode if no malfunction is detected in user mode.

Is malfunctioning part detected?

- YES >> Refer to [SRC-70, "Diagnosis Procedure"](#).  
NO >> INSPECTION END

### Diagnosis Procedure

INFOID:000000006450365

#### WARNING:

- Before servicing, turn ignition switch OFF, disconnect battery negative terminal and wait at least 3 minutes. (To discharge backup capacitor.)
- Never use unspecified tester or other measuring device.

#### 1. CHECK HARNESS CONNECTOR

Check the harness connector.

Is the inspection result normal?

- YES >> GO TO 2.  
NO >> Replace harness connector.

#### 2. CHECK WIRING HARNESS

Check the wiring harness externals.

Is the inspection result normal?

## B1086 PRE-TEN FRONT LH

### < DTC/CIRCUIT DIAGNOSIS >

---

YES >> GO TO 3.

NO >> Replace wiring harness.

### 3.REPLACE FRONT SEAT BELT PRE-TENSIONER

---

1. Replace front LH seat belt pre-tensioner. Refer to [SB-6. "SEAT BELT RETRACTOR : Exploded View"](#).

2. Perform DTC confirmation procedure. Refer to [SRC-70. "DTC Logic"](#).

#### Is DTC detected?

YES >> GO TO 4.

NO >> INSPECTION END

### 4.REPLACE AIR BAG DIAGNOSIS SENSOR UNIT

---

1. Replace air bag diagnosis sensor unit. Refer to [SR-23. "Exploded View"](#).

2. Perform DTC confirmation procedure. Refer to [SRC-70. "DTC Logic"](#).

#### Is DTC detected?

YES >> GO TO 1.

NO >> INSPECTION END

A  
B  
C  
D  
E  
F  
G  
I  
J  
K  
L  
M  
N  
O  
P

SRC

# B1087 PRE-TEN FRONT LH

< DTC/CIRCUIT DIAGNOSIS >

## B1087 PRE-TEN FRONT LH

### Description

INFOID:000000006450366

For front LH seat belt pre-tensioner, crash is judged by main "G" sensor output signal and safing algorithm in front direction.

### OPERATION

In the case of a frontal collision that exceeds specified impact level, the air bag diagnosis sensor unit detects the deceleration caused by collision. It restrains the passenger with seat belt easing the stress on passengers chest with load limiter.

### STRUCTURE

The restraint system for front seat occupant consists of the pre-tensioner mechanism and load limiter mechanism.

### INSTALLATION

Front LH seat belt pre-tensioner is installed on the underside of center pillar with fixed nuts.

### DTC Logic

INFOID:000000006450367

DTC No.	Trouble diagnosis name	DTC detecting condition	Possible cause
B1087	PRE-TEN FRONT LH [VB-SHORT]	Front LH seat belt pre-tensioner circuit is shorted to some power supply circuit	<ul style="list-style-type: none"><li>• Disconnection of wiring harness and short</li><li>• Malfunction in front LH seat belt pre-tensioner</li><li>• Malfunction in air bag diagnosis sensor unit</li></ul>

### DTC CONFIRMATION PROCEDURE

#### 1. CHECK SELF-DIAG RESULT

With CONSULT-III

1. Turn ignition switch ON.
2. Perform "AIR BAG" Self Diagnostic Result.

Without CONSULT-III

1. Turn ignition switch ON.
2. Check the air bag warning lamp status. Refer to [SRC-14, "Air Bag Warning Lamp Diagnosis"](#).

#### NOTE:

SRS does not enter diagnosis mode if no malfunction is detected in user mode.

Is malfunctioning part detected?

YES >> Refer to [SRC-72, "Diagnosis Procedure"](#).

NO >> INSPECTION END

### Diagnosis Procedure

INFOID:000000006450368

#### WARNING:

- Before servicing, turn ignition switch OFF, disconnect battery negative terminal and wait at least 3 minutes. (To discharge backup capacitor.)
- Never use unspecified tester or other measuring device.

#### 1. CHECK HARNESS CONNECTOR

Check the harness connector.

Is the inspection result normal?

YES >> GO TO 2.

NO >> Replace harness connector.

#### 2. CHECK WIRING HARNESS

Check the wiring harness externals.

Is the inspection result normal?



## B1087 PRE-TEN FRONT LH

### < DTC/CIRCUIT DIAGNOSIS >

---

- YES >> GO TO 3.  
NO >> Replace wiring harness.

### 3.REPLACE FRONT SEAT BELT PRE-TENSIONER

---

1. Replace front LH seat belt pre-tensioner. Refer to [SB-6. "SEAT BELT RETRACTOR : Exploded View"](#).
2. Perform DTC confirmation procedure. Refer to [SRC-72. "DTC Logic"](#).

#### Is DTC detected?

- YES >> GO TO 4.  
NO >> INSPECTION END

### 4.REPLACE AIR BAG DIAGNOSIS SENSOR UNIT

---

1. Replace air bag diagnosis sensor unit. Refer to [SR-23. "Exploded View"](#).
2. Perform DTC confirmation procedure. Refer to [SRC-72. "DTC Logic"](#).

#### Is DTC detected?

- YES >> GO TO 1.  
NO >> INSPECTION END

A  
B  
C  
D  
E  
F  
G  
I  
J  
K  
L  
M  
N  
O  
P

SRC

# B1088 PRE-TEN FRONT LH

< DTC/CIRCUIT DIAGNOSIS >

## B1088 PRE-TEN FRONT LH

### Description

INFOID:000000006450369

For front LH seat belt pre-tensioner, crash is judged by main "G" sensor output signal and safing algorithm in front direction.

### OPERATION

In the case of a frontal collision that exceeds specified impact level, the air bag diagnosis sensor unit detects the deceleration caused by collision. It restrains the passenger with seat belt easing the stress on passengers chest with load limiter.

### STRUCTURE

The restraint system for front seat occupant consists of the pre-tensioner mechanism and load limiter mechanism.

### INSTALLATION

Front LH seat belt pre-tensioner is installed on the underside of center pillar with fixed nuts.

### DTC Logic

INFOID:000000006450370

DTC No.	Trouble diagnosis name	DTC detecting condition	Possible cause
B1088	PRE-TEN FRONT LH [GND-SHORT]	Front LH seat belt pre-tensioner circuit is shorted to ground	<ul style="list-style-type: none"><li>• Disconnection of wiring harness and short</li><li>• Malfunction in front LH seat belt pre-tensioner</li><li>• Malfunction in air bag diagnosis sensor unit</li></ul>

### DTC CONFIRMATION PROCEDURE

#### 1. CHECK SELF-DIAG RESULT

With CONSULT-III

1. Turn ignition switch ON.
2. Perform "AIR BAG" Self Diagnostic Result.

Without CONSULT-III

1. Turn ignition switch ON.
2. Check the air bag warning lamp status. Refer to [SRC-14, "Air Bag Warning Lamp Diagnosis"](#).

#### NOTE:

SRS does not enter diagnosis mode if no malfunction is detected in user mode.

Is malfunctioning part detected?

- YES >> Refer to [SRC-74, "Diagnosis Procedure"](#).  
NO >> INSPECTION END

### Diagnosis Procedure

INFOID:000000006450371

#### WARNING:

- Before servicing, turn ignition switch OFF, disconnect battery negative terminal and wait at least 3 minutes. (To discharge backup capacitor.)
- Never use unspecified tester or other measuring device.

#### 1. CHECK HARNESS CONNECTOR

Check the harness connector.

Is the inspection result normal?

- YES >> GO TO 2.  
NO >> Replace harness connector.

#### 2. CHECK WIRING HARNESS

Check the wiring harness externals.

Is the inspection result normal?

## B1088 PRE-TEN FRONT LH

### < DTC/CIRCUIT DIAGNOSIS >

---

YES >> GO TO 3.

NO >> Replace wiring harness.

### 3.REPLACE FRONT SEAT BELT PRE-TENSIONER

---

1. Replace front LH seat belt pre-tensioner. Refer to [SB-6. "SEAT BELT RETRACTOR : Exploded View"](#).

2. Perform DTC confirmation procedure. Refer to [SRC-74. "DTC Logic"](#).

#### Is DTC detected?

YES >> GO TO 4.

NO >> INSPECTION END

### 4.REPLACE AIR BAG DIAGNOSIS SENSOR UNIT

---

1. Replace air bag diagnosis sensor unit. Refer to [SR-23. "Exploded View"](#).

2. Perform DTC confirmation procedure. Refer to [SRC-74. "DTC Logic"](#).

#### Is DTC detected?

YES >> GO TO 1.

NO >> INSPECTION END

A  
B  
C  
D  
E  
F  
G  
I  
J  
K  
L  
M  
N  
O  
P

SRC

# B1089 PRE-TEN FRONT LH

< DTC/CIRCUIT DIAGNOSIS >

## B1089 PRE-TEN FRONT LH

### Description

INFOID:000000006450372

For front LH seat belt pre-tensioner, crash is judged by main "G" sensor output signal and safing algorithm in front direction.

### OPERATION

In the case of a frontal collision that exceeds specified impact level, the air bag diagnosis sensor unit detects the deceleration caused by collision. It restrains the passenger with seat belt easing the stress on passengers chest with load limiter.

### STRUCTURE

The restraint system for front seat occupant consists of the pre-tensioner mechanism and load limiter mechanism.

### INSTALLATION

Front LH seat belt pre-tensioner is installed on the underside of center pillar with fixed nuts.

### DTC Logic

INFOID:000000006450373

DTC No.	Trouble diagnosis name	DTC detecting condition	Possible cause
B1089	PRE-TEN FRONT LH [SHORT]	Front LH seat belt pre-tensioner circuit are shorted to each other	<ul style="list-style-type: none"><li>• Disconnection of wiring harness and short</li><li>• Malfunction in front LH seat belt pre-tensioner</li><li>• Malfunction in air bag diagnosis sensor unit</li></ul>

### DTC CONFIRMATION PROCEDURE

#### 1. CHECK SELF-DIAG RESULT

With CONSULT-III

1. Turn ignition switch ON.
2. Perform "AIR BAG" Self Diagnostic Result.

Without CONSULT-III

1. Turn ignition switch ON.
2. Check the air bag warning lamp status. Refer to [SRC-14, "Air Bag Warning Lamp Diagnosis"](#).

#### NOTE:

SRS does not enter diagnosis mode if no malfunction is detected in user mode.

Is malfunctioning part detected?

- YES >> Refer to [SRC-76, "Diagnosis Procedure"](#).  
NO >> INSPECTION END

### Diagnosis Procedure

INFOID:000000006450374

#### WARNING:

- Before servicing, turn ignition switch OFF, disconnect battery negative terminal and wait at least 3 minutes. (To discharge backup capacitor.)
- Never use unspecified tester or other measuring device.

#### 1. CHECK HARNESS CONNECTOR

Check the harness connector.

Is the inspection result normal?

- YES >> GO TO 2.  
NO >> Replace harness connector.

#### 2. CHECK WIRING HARNESS

Check the wiring harness externals.

Is the inspection result normal?

# B1089 PRE-TEN FRONT LH

## < DTC/CIRCUIT DIAGNOSIS >

---

- YES >> GO TO 3.
- NO >> Replace wiring harness.

### 3.REPLACE FRONT SEAT BELT PRE-TENSIONER

---

1. Replace front LH seat belt pre-tensioner. Refer to [SB-6. "SEAT BELT RETRACTOR : Exploded View"](#).
2. Perform DTC confirmation procedure. Refer to [SRC-76. "DTC Logic"](#).

#### Is DTC detected?

- YES >> GO TO 4.
- NO >> INSPECTION END

### 4.REPLACE AIR BAG DIAGNOSIS SENSOR UNIT

---

1. Replace air bag diagnosis sensor unit. Refer to [SR-23. "Exploded View"](#).
2. Perform DTC confirmation procedure. Refer to [SRC-76. "DTC Logic"](#).

#### Is DTC detected?

- YES >> GO TO 1.
- NO >> INSPECTION END

A  
B  
C  
D  
E  
F  
G  
I  
J  
K  
L  
M  
N  
O  
P

SRC

# B1106, B1107, B1108, B1109, B1110, B1111 DIAGNOSIS SENSOR UNIT

< DTC/CIRCUIT DIAGNOSIS >

## B1106, B1107, B1108, B1109, B1110, B1111 DIAGNOSIS SENSOR UNIT

### Description

INFOID:000000006450375

Checks the entire SRS and displays the malfunction either by illuminating or blinking the air bag warning lamp on the combination meter. Malfunctioning part can be detected by on board self-diagnosis system and CONSULT-III.

### OPERATION

It detects a shock that exceeds a specified level and monitors whether the driver and passenger air bags, front side air bag, side curtain air bag and pre-tensioner seat belts operate normally.

### STRUCTURE

It contains the "G" sensors for both frontal and side collisions and spare battery function in case of main battery damage in collision.

### INSTALLATION

Air bag diagnosis sensor unit is installed under the center console with fixed bolts.

### DTC Logic

INFOID:000000006450376

DTC No.	Trouble diagnosis name	DTC detecting condition	Possible cause
B1106 B1107 B1108 B1109 B1110 B1111	CONTROL UNIT	Air bag diagnosis sensor unit is malfunctioning or out of the specification	<ul style="list-style-type: none"><li>Malfunction in air bag diagnosis sensor unit</li><li>Configuration in air bag diagnosis sensor unit does not match the vehicle specification</li></ul>

### DTC CONFIRMATION PROCEDURE

#### 1. CHECK SELF-DIAG RESULT

With CONSULT-III

- Turn ignition switch ON.
- Perform "AIR BAG" Self Diagnostic Result.

Without CONSULT-III

- Turn ignition switch ON.
- Check the air bag warning lamp status. Refer to [SRC-14, "Air Bag Warning Lamp Diagnosis"](#).

#### NOTE:

SRS does not enter diagnosis mode if no malfunction is detected in user mode.

Is malfunctioning part detected?

YES >> Refer to [SRC-78, "Diagnosis Procedure"](#).

NO >> INSPECTION END

### Diagnosis Procedure

INFOID:000000006450377

#### WARNING:

- Before servicing, turn ignition switch OFF, disconnect battery negative terminal and wait at least 3 minutes. (To discharge backup capacitor.)
- Never use unspecified tester or other measuring device.

#### 1. CHECK HARNESS CONNECTOR

Check the harness connector.

Is the inspection result normal?

YES >> GO TO 2.

NO >> Replace harness connectors.

#### 2. CHECK WIRING HARNESS

Check the wiring harness externals.

Is the inspection result normal?

# B1106, B1107, B1108, B1109, B1110, B1111 DIAGNOSIS SENSOR UNIT

## < DTC/CIRCUIT DIAGNOSIS >

---

YES >> GO TO 3.

NO >> Replace wiring harness.

### 3. REPLACE AIR BAG DIAGNOSIS SENSOR UNIT

---

1. Replace air bag diagnosis sensor unit. Refer to [SR-23. "Exploded View"](#).

2. Perform DTC confirmation procedure. Refer to [SRC-78. "DTC Logic"](#).

#### Is DTC detected?

YES >> GO TO 1.

NO >> INSPECTION END

A

B

C

D

E

F

G

SRC

I

J

K

L

M

N

O

P

# B1113, B1114 SATELLITE SENS RH

< DTC/CIRCUIT DIAGNOSIS >

## B1113, B1114 SATELLITE SENS RH

### Description

INFOID:000000006450378

Main "G" sensor generates signal voltage, when it detects deceleration beyond the specified level by vehicle side collision.

### OPERATION

When air bag diagnosis sensor unit defines both signal voltage of the "G" sensor and the safing algorithm to be that of collision which exceeds a specified level, the driving circuit switches on and feeds the electric ignitor of both the front side air bag and side curtain air bag.

### STRUCTURE

Integrated type of the "G" sensor element for side collision with output terminals for signal voltage.

### INSTALLATION

RH satellite sensor is installed at the underside of center pillar with fixed nuts.

### DTC Logic

INFOID:000000006450379

DTC No.	Trouble diagnosis name	DTC detecting condition	Possible cause
B1113 B1114	SATELLITE SENS RH [UNIT FAIL]	RH satellite sensor is malfunctioning	<ul style="list-style-type: none"><li>• Disconnection of wiring harness</li><li>• Malfunction in RH satellite sensor</li><li>• Malfunction in air bag diagnosis sensor unit</li></ul>

### DTC CONFIRMATION PROCEDURE

#### 1. CHECK SELF-DIAG RESULT

With CONSULT-III

1. Turn ignition switch ON.
2. Perform "AIR BAG" Self Diagnostic Result.

Without CONSULT-III

1. Turn ignition switch ON.
2. Check the air bag warning lamp status. Refer to [SRC-14. "Air Bag Warning Lamp Diagnosis"](#).

#### NOTE:

SRS does not enter diagnosis mode if no malfunction is detected in user mode.

Is malfunctioning part detected?

- YES >> Refer to [SRC-80. "Diagnosis Procedure"](#).  
NO >> INSPECTION END

### Diagnosis Procedure

INFOID:000000006450380

#### WARNING:

- Before servicing, turn ignition switch OFF, disconnect battery negative terminal and wait at least 3 minutes. (To discharge backup capacitor.)
- Never use unspecified tester or other measuring device.

#### 1. CHECK HARNESS CONNECTOR

Check the harness connector.

Is the inspection result normal?

- YES >> GO TO 2.  
NO >> Replace harness connector.

#### 2. CHECK WIRING HARNESS

Check the wiring harness externals.

Is the inspection result normal?

- YES >> GO TO 3.  
NO >> Replace wiring harness.



# B1113, B1114 SATELLITE SENS RH

< DTC/CIRCUIT DIAGNOSIS >

---

## 3. REPLACE SATELLITE SENSOR

---

1. Replace RH satellite sensor. Refer to [SR-22, "Exploded View"](#).
2. Perform DTC confirmation procedure. Refer to [SRC-80, "DTC Logic"](#).

Is DTC detected?

- YES >> GO TO 4.  
NO >> INSPECTION END

## 4. REPLACE AIR BAG DIAGNOSIS SENSOR UNIT

---

1. Replace air bag diagnosis sensor unit. Refer to [SR-23, "Exploded View"](#).
2. Perform DTC confirmation procedure. Refer to [SRC-80, "DTC Logic"](#).

Is DTC detected?

- YES >> GO TO 1.  
NO >> INSPECTION END

A  
B  
C  
D  
E  
F  
G  
I  
J  
K  
L  
M  
N  
O  
P

SRC

# B1115, B1116 SATELLITE SENS RH

< DTC/CIRCUIT DIAGNOSIS >

## B1115, B1116 SATELLITE SENS RH

### Description

INFOID:000000006450381

Main "G" sensor generates signal voltage, when it detects deceleration beyond the specified level by vehicle side collision.

### OPERATION

When air bag diagnosis sensor unit defines both signal voltage of the "G" sensor and the safing algorithm to be that of collision which exceeds a specified level, the driving circuit switches on and feeds the electric ignitor of both the front side air bag and side curtain air bag.

### STRUCTURE

Integrated type of the "G" sensor element for side collision with output terminals for signal voltage.

### INSTALLATION

RH satellite sensor is installed at the underside of center pillar with fixed nuts.

### DTC Logic

INFOID:000000006450382

DTC No.	Trouble diagnosis name	DTC detecting condition	Possible cause
B1115 B1116	SATELLITE SENS RH [COMM FAIL] [UNMATCH]	RH satellite sensor is malfunctioning or out of the specified specification	<ul style="list-style-type: none"><li>• Disconnection of wiring harness</li><li>• Malfunction in RH satellite sensor</li><li>• Malfunction in air bag diagnosis sensor unit</li></ul>

### DTC CONFIRMATION PROCEDURE

#### 1. CHECK SELF-DIAG RESULT

With CONSULT-III

1. Turn ignition switch ON.
2. Perform "AIR BAG" Self Diagnostic Result.

Without CONSULT-III

1. Turn ignition switch ON.
2. Check the air bag warning lamp status. Refer to [SRC-14. "Air Bag Warning Lamp Diagnosis"](#).

#### NOTE:

SRS does not enter diagnosis mode if no malfunction is detected in user mode.

Is malfunctioning part detected?

- YES >> Refer to [SRC-82. "Diagnosis Procedure"](#).  
NO >> INSPECTION END

### Diagnosis Procedure

INFOID:000000006450383

#### WARNING:

- Before servicing, turn ignition switch OFF, disconnect battery negative terminal and wait at least 3 minutes. (To discharge backup capacitor.)
- Never use unspecified tester or other measuring device.

#### 1. CHECK HARNESS CONNECTOR

Check the harness connector.

Is the inspection result normal?

- YES >> GO TO 2.  
NO >> Replace harness connector.

#### 2. CHECK WIRING HARNESS

Check the wiring harness externals.

Is the inspection result normal?

- YES >> GO TO 3.  
NO >> Replace wiring harness.

# B1115, B1116 SATELLITE SENS RH

< DTC/CIRCUIT DIAGNOSIS >

---

## 3. REPLACE SATELLITE SENSOR

---

1. Replace RH satellite sensor. Refer to [SR-22, "Exploded View"](#).
2. Perform DTC confirmation procedure. Refer to [SRC-82, "DTC Logic"](#).

Is DTC detected?

- YES >> GO TO 4.  
NO >> INSPECTION END

## 4. REPLACE AIR BAG DIAGNOSIS SENSOR UNIT

---

1. Replace air bag diagnosis sensor unit. Refer to [SR-23, "Exploded View"](#).
2. Perform DTC confirmation procedure. Refer to [SRC-82, "DTC Logic"](#).

Is DTC detected?

- YES >> GO TO 1.  
NO >> INSPECTION END

A  
B  
C  
D  
E  
F  
G  
I  
J  
K  
L  
M  
N  
O  
P

SRC

# B1118, B1119 SATELLITE SENS LH

< DTC/CIRCUIT DIAGNOSIS >

## B1118, B1119 SATELLITE SENS LH

### Description

INFOID:000000006450384

Main "G" sensor generates signal voltage, when it detects deceleration beyond the specified level by vehicle side collision.

### OPERATION

When air bag diagnosis sensor unit defines both signal voltage of the "G" sensor and the safing algorithm to be that of collision which exceeds a specified level, the driving circuit switches on and feeds the electric ignitor of both the front side air bag and side curtain air bag.

### STRUCTURE

Integrated type of the "G" sensor element for side collision with output terminals for signal voltage.

### INSTALLATION

LH satellite sensor is installed at the underside of center pillar with fixed nuts.

### DTC Logic

INFOID:000000006450385

DTC No.	Trouble diagnosis name	DTC detecting condition	Possible cause
B1118 B1119	SATELLITE SENS LH [UNIT FAIL]	LH satellite sensor is malfunctioning	<ul style="list-style-type: none"><li>• Disconnection of wiring harness</li><li>• Malfunction in LH satellite sensor</li><li>• Malfunction in air bag diagnosis sensor unit</li></ul>

### DTC CONFIRMATION PROCEDURE

#### 1. CHECK SELF-DIAG RESULT

With CONSULT-III

1. Turn ignition switch ON.
2. Perform "AIR BAG" Self Diagnostic Result.

Without CONSULT-III

1. Turn ignition switch ON.
2. Check the air bag warning lamp status. Refer to [SRC-14. "Air Bag Warning Lamp Diagnosis"](#).

#### NOTE:

SRS does not enter diagnosis mode if no malfunction is detected in user mode.

Is malfunctioning part detected?

- YES >> Refer to [SRC-84. "Diagnosis Procedure"](#).  
NO >> INSPECTION END

### Diagnosis Procedure

INFOID:000000006450386

#### WARNING:

- Before servicing, turn ignition switch OFF, disconnect battery negative terminal and wait at least 3 minutes. (To discharge backup capacitor.)
- Never use unspecified tester or other measuring device.

#### 1. CHECK HARNESS CONNECTOR

Check the harness connector.

Is the inspection result normal?

- YES >> GO TO 2.  
NO >> Replace harness connector.

#### 2. CHECK WIRING HARNESS

Check the wiring harness externals.

Is the inspection result normal?

- YES >> GO TO 3.  
NO >> Replace wiring harness.

## B1118, B1119 SATELLITE SENS LH

< DTC/CIRCUIT DIAGNOSIS >

---

### 3. REPLACE SATELLITE SENSOR

---

1. Replace LH satellite sensor. Refer to [SR-22, "Exploded View"](#).
2. Perform DTC confirmation procedure. Refer to [SRC-84, "DTC Logic"](#)

Is DTC detected?

- YES >> GO TO 4.  
NO >> INSPECTION END

### 4. REPLACE AIR BAG DIAGNOSIS SENSOR UNIT

---

1. Replace air bag diagnosis sensor unit. Refer to [SR-23, "Exploded View"](#).
2. Perform DTC confirmation procedure. Refer to [SRC-84, "DTC Logic"](#).

Is DTC detected?

- YES >> GO TO 1.  
NO >> INSPECTION END

A  
B  
C  
D  
E  
F  
G  
I  
J  
K  
L  
M  
N  
O  
P

SRC

# B1120, B1121 SATELLITE SENS LH

< DTC/CIRCUIT DIAGNOSIS >

## B1120, B1121 SATELLITE SENS LH

### Description

INFOID:000000006450387

Main "G" sensor generates signal voltage, when it detects deceleration beyond the specified level by vehicle side collision.

### OPERATION

When air bag diagnosis sensor unit defines both signal voltage of the "G" sensor and the safing algorithm to be that of collision which exceeds a specified level, the driving circuit switches on and feeds the electric ignitor of both the front side air bag and side curtain air bag.

### STRUCTURE

Integrated type of the "G" sensor element for side collision with output terminals for signal voltage.

### INSTALLATION

LH satellite sensor is installed at the underside of center pillar with fixed nuts.

### DTC Logic

INFOID:000000006450388

DTC No.	Trouble diagnosis name	DTC detecting condition	Possible cause
B1120 B1121	SATELLITE SENS LH [COMM FAIL] [UNMATCH]	LH satellite sensor is malfunctioning or out of the specified specification	<ul style="list-style-type: none"><li>• Disconnection of wiring harness</li><li>• Malfunction in LH satellite sensor</li><li>• Malfunction in air bag diagnosis sensor unit</li></ul>

### DTC CONFIRMATION PROCEDURE

#### 1. CHECK SELF-DIAG RESULT

With CONSULT-III

1. Turn ignition switch ON.
2. Perform "AIR BAG" Self Diagnostic Result.

Without CONSULT-III

1. Turn ignition switch ON.
2. Check the air bag warning lamp status. Refer to [SRC-14. "Air Bag Warning Lamp Diagnosis"](#).

#### NOTE:

SRS does not enter diagnosis mode if no malfunction is detected in user mode.

Is malfunctioning part detected?

- YES >> Refer to [SRC-86. "Diagnosis Procedure"](#).  
NO >> INSPECTION END

### Diagnosis Procedure

INFOID:000000006450389

#### WARNING:

- Before servicing, turn ignition switch OFF, disconnect battery negative terminal and wait at least 3 minutes. (To discharge backup capacitor.)
- Never use unspecified tester or other measuring device.

#### 1. CHECK HARNESS CONNECTOR

Check the harness connector.

Is the inspection result normal?

- YES >> GO TO 2.  
NO >> Replace harness connector.

#### 2. CHECK WIRING HARNESS

Check the wiring harness externals.

Is the inspection result normal?

- YES >> GO TO 3.  
NO >> Replace wiring harness.

## B1120, B1121 SATELLITE SENS LH

< DTC/CIRCUIT DIAGNOSIS >

---

### 3.REPLACE SATELLITE SENSOR

---

1. Replace LH satellite sensor. Refer to [SR-22. "Exploded View"](#).
2. Perform DTC confirmation procedure. Refer to [SRC-86. "DTC Logic"](#).

Is DTC detected?

- YES >> GO TO 4.  
NO >> INSPECTION END

### 4.REPLACE AIR BAG DIAGNOSIS SENSOR UNIT

---

1. Replace air bag diagnosis sensor unit. Refer to [SR-23. "Exploded View"](#).
2. Perform DTC confirmation procedure. Refer to [SRC-86. "DTC Logic"](#).

Is DTC detected?

- YES >> GO TO 1.  
NO >> INSPECTION END

A  
B  
C  
D  
E  
F  
G  
I  
J  
K  
L  
M  
N  
O  
P

SRC

# B1122, B1123, B1124, B1125, B1126, B1127 DIAGNOSIS SENSOR UNIT

< DTC/CIRCUIT DIAGNOSIS >

## B1122, B1123, B1124, B1125, B1126, B1127 DIAGNOSIS SENSOR UNIT

### Description

INFOID:000000006450390

Checks the entire SRS and displays the malfunction either by illuminating or blinking the air bag warning lamp on the combination meter. Malfunctioning part can be detected by on board self-diagnosis system and CONSULT-III.

### OPERATION

It detects a shock that exceeds a specified level and monitors whether the driver and passenger air bags, front side air bag, side curtain air bag and pre-tensioner seat belts operate normally.

### STRUCTURE

It contains the "G" sensors for both frontal and side collisions and spare battery function in case of main battery damage in collision.

### INSTALLATION

Air bag diagnosis sensor unit is installed under the center console with fixed bolts.

### DTC Logic

INFOID:000000006450391

DTC No.	Trouble diagnosis name	DTC detecting condition	Possible cause
B1122 B1123 B1124 B1125 B1126 B1127	CONTROL UNIT	Air bag diagnosis sensor unit is malfunctioning or out of the specification	<ul style="list-style-type: none"><li>Malfunction in air bag diagnosis sensor unit</li><li>Configuration in air bag diagnosis sensor unit does not match the vehicle specification</li></ul>

### DTC CONFIRMATION PROCEDURE

#### 1. CHECK SELF-DIAG RESULT

With CONSULT-III

- Turn ignition switch ON.
- Perform "AIR BAG" Self Diagnostic Result.

Without CONSULT-III

- Turn ignition switch ON.
- Check the air bag warning lamp status. Refer to [SRC-14, "Air Bag Warning Lamp Diagnosis"](#).

#### NOTE:

SRS does not enter diagnosis mode if no malfunction is detected in user mode.

Is malfunctioning part detected?

YES >> Refer to [SRC-88, "Diagnosis Procedure"](#).

NO >> INSPECTION END

### Diagnosis Procedure

INFOID:000000006450392

#### WARNING:

- Before servicing, turn ignition switch OFF, disconnect battery negative terminal and wait at least 3 minutes. (To discharge backup capacitor.)
- Never use unspecified tester or other measuring device.

#### 1. CHECK HARNESS CONNECTOR

Check the harness connector.

Is the inspection result normal?

YES >> GO TO 2.

NO >> Replace harness connectors.

#### 2. CHECK WIRING HARNESS

Check the wiring harness externals.

Is the inspection result normal?



# B1122, B1123, B1124, B1125, B1126, B1127 DIAGNOSIS SENSOR UNIT

## < DTC/CIRCUIT DIAGNOSIS >

---

YES >> GO TO 3.

NO >> Replace wiring harness.

### 3. REPLACE AIR BAG DIAGNOSIS SENSOR UNIT

---

1. Replace air bag diagnosis sensor unit. Refer to [SR-23. "Exploded View"](#).

2. Perform DTC confirmation procedure. Refer to [SRC-88. "DTC Logic"](#).

#### Is DTC detected?

YES >> GO TO 1.

NO >> INSPECTION END

A

B

C

D

E

F

G

SRC

I

J

K

L

M

N

O

P

# B1129 SIDE MODULE RH

< DTC/CIRCUIT DIAGNOSIS >

## B1129 SIDE MODULE RH

### Description

INFOID:000000006450393

For front RH side air bag module, crash is judged by main "G" sensor output signal (left side: LH satellite sensor, right side: RH satellite sensor) and safing algorithm (in air bag diagnosis sensor unit).

### OPERATION

In case of frontal collision whose acceleration exceeds the specified level, the ignition materials are ignited by electric ignition system. The system burns the gas generating materials resulting in a chemical reaction. This generates hot gases that flow into the air bag through a filter and expand the bag.

### STRUCTURE

Front RH side air bag module mainly consists of air bag and inflator that inflates air bag.

### INSTALLATION

Front RH side air bag module is installed on the side of front seat back with fixed nuts.

### DTC Logic

INFOID:000000006450394

DTC No.	Trouble diagnosis name	DTC detecting condition	Possible cause
B1129	SIDE MODULE RH [OPEN]	Front RH side air bag module circuit is open	<ul style="list-style-type: none"><li>• Disconnection of wiring harness and open</li><li>• Malfunction in front RH side air bag module</li><li>• Malfunction in air bag diagnosis sensor unit</li></ul>

### DTC CONFIRMATION PROCEDURE

#### 1. CHECK SELF-DIAG RESULT

Ⓟ With CONSULT-III

1. Turn ignition switch ON.
2. Perform "AIR BAG" Self Diagnostic Result.

ⓧ Without CONSULT-III

1. Turn ignition switch ON.
2. Check the air bag warning lamp status. [SRC-14, "Air Bag Warning Lamp Diagnosis"](#)

#### NOTE:

SRS does not enter diagnosis mode if no malfunction is detected in user mode.

Is malfunctioning part detected?

- YES >> Refer to [SRC-90, "Diagnosis Procedure"](#).  
NO >> INSPECTION END

### Diagnosis Procedure

INFOID:000000006450395

#### WARNING:

- Before servicing, turn ignition switch OFF, disconnect battery negative terminal and wait at least 3 minutes. (To discharge backup capacitor.)
- Never use unspecified tester or other measuring device.

#### 1. CHECK HARNESS CONNECTOR

Check the harness connector.

Is the inspection result normal?

- YES >> GO TO 2.  
NO >> Replace harness connector.

#### 2. CHECK WIRING HARNESS

Check the wiring harness externals.

Is the inspection result normal?

- YES >> GO TO 3.

## B1129 SIDE MODULE RH

### < DTC/CIRCUIT DIAGNOSIS >

---

NO >> Replace wiring harness.

### 3.REPLACE AIR BAG DIAGNOSIS SENSOR UNIT

---

1. Replace air bag diagnosis sensor unit. Refer to [SR-23, "Exploded View"](#).
2. Perform DTC confirmation procedure. Refer to [SRC-90, "DTC Logic"](#).

#### Is DTC detected?

YES >> GO TO 4.

NO >> INSPECTION END

---

### 4.REPLACE FRONT SIDE AIR BAG MODULE

---

1. Replace front RH side air bag module. Refer to [SE-188, "Exploded View"](#).
2. Perform DTC confirmation procedure. Refer to [SRC-90, "DTC Logic"](#).

#### Is DTC detected?

YES >> GO TO 1.

NO >> INSPECTION END

A  
B  
C  
D  
E  
F  
G  
I  
J  
K  
L  
M  
N  
O  
P

SRC

# B1130 SIDE MODULE RH

< DTC/CIRCUIT DIAGNOSIS >

## B1130 SIDE MODULE RH

### Description

INFOID:000000006450396

For front RH side air bag module, crash is judged by main "G" sensor output signal (left side: LH satellite sensor, right side: RH satellite sensor) and safing algorithm (in air bag diagnosis sensor unit).

### OPERATION

In case of frontal collision whose acceleration exceeds the specified level, the ignition materials are ignited by electric ignition system. The system burns the gas generating materials resulting in a chemical reaction. This generates hot gases that flow into the air bag through a filter and expand the bag.

### STRUCTURE

Front RH side air bag module mainly consists of air bag and inflator that inflates air bag.

### INSTALLATION

Front RH side air bag module is installed on the side of front seat back with fixed nuts.

### DTC Logic

INFOID:000000006450397

DTC No.	Trouble diagnosis name	DTC detecting condition	Possible cause
B1130	SIDE MODULE RH [VB-SHORT]	Front RH side air bag module circuit is shorted to some power supply circuit	<ul style="list-style-type: none"><li>• Disconnection of wiring harness and short</li><li>• Malfunction in front RH side air bag module</li><li>• Malfunction in air bag diagnosis sensor unit</li></ul>

### DTC CONFIRMATION PROCEDURE

#### 1. CHECK SELF-DIAG RESULT

Ⓟ With CONSULT-III

1. Turn ignition switch ON.
2. Perform "AIR BAG" Self Diagnostic Result.

ⓧ Without CONSULT-III

1. Turn ignition switch ON.
2. Check the air bag warning lamp status. Refer to [SRC-14, "Air Bag Warning Lamp Diagnosis"](#).

#### NOTE:

SRS does not enter diagnosis mode if no malfunction is detected in user mode.

Is malfunctioning part detected?

- YES >> Refer to [SRC-92, "Diagnosis Procedure"](#).  
NO >> INSPECTION END

### Diagnosis Procedure

INFOID:000000006450398

#### WARNING:

- Before servicing, turn ignition switch OFF, disconnect battery negative terminal and wait at least 3 minutes. (To discharge backup capacitor.)
- Never use unspecified tester or other measuring device.

#### 1. CHECK HARNESS CONNECTOR

Check the harness connector.

Is the inspection result normal?

- YES >> GO TO 2.  
NO >> Replace harness connector.

#### 2. CHECK WIRING HARNESS

Check the wiring harness externals.

Is the inspection result normal?

- YES >> GO TO 3.

## B1130 SIDE MODULE RH

### < DTC/CIRCUIT DIAGNOSIS >

---

NO >> Replace wiring harness.

### 3.REPLACE AIR BAG DIAGNOSIS SENSOR UNIT

---

1. Replace air bag diagnosis sensor unit. Refer to [SR-23, "Exploded View"](#).
2. Perform DTC confirmation procedure. Refer to [SRC-92, "DTC Logic"](#).

#### Is DTC detected?

YES >> GO TO 4.

NO >> INSPECTION END

---

### 4.REPLACE FRONT SIDE AIR BAG MODULE

---

1. Replace front RH side air bag module. Refer to [SE-188, "Exploded View"](#).
2. Perform DTC confirmation procedure. Refer to [SRC-92, "DTC Logic"](#).

#### Is DTC detected?

YES >> GO TO 1.

NO >> INSPECTION END

A  
B  
C  
D  
E  
F  
G  
I  
J  
K  
L  
M  
N  
O  
P

SRC

# B1131 SIDE MODULE RH

< DTC/CIRCUIT DIAGNOSIS >

## B1131 SIDE MODULE RH

### Description

INFOID:000000006450399

For front RH side air bag module, crash is judged by main "G" sensor output signal (left side: LH satellite sensor, right side: RH satellite sensor) and safing algorithm (in air bag diagnosis sensor unit).

### OPERATION

In case of frontal collision whose acceleration exceeds the specified level, the ignition materials are ignited by electric ignition system. The system burns the gas generating materials resulting in a chemical reaction. This generates hot gases that flow into the air bag through a filter and expand the bag.

### STRUCTURE

Front RH side air bag module mainly consists of air bag and inflator that inflates air bag.

### INSTALLATION

Front RH side air bag module is installed on the side of front seat back with fixed nuts.

### DTC Logic

INFOID:000000006450400

DTC No.	Trouble diagnosis name	DTC detecting condition	Possible cause
B1131	SIDE MODULE RH [GND-SHORT]	Front RH side air bag module circuit is shorted to ground	<ul style="list-style-type: none"><li>• Disconnection of wiring harness and short</li><li>• Malfunction in front RH side air bag module</li><li>• Malfunction in air bag diagnosis sensor unit</li></ul>

### DTC CONFIRMATION PROCEDURE

#### 1. CHECK SELF-DIAG RESULT

Ⓟ With CONSULT-III

1. Turn ignition switch ON.
2. Perform "AIR BAG" Self Diagnostic Result.

ⓧ Without CONSULT-III

1. Turn ignition switch ON.
2. Check the air bag warning lamp status. Refer to [SRC-14, "Air Bag Warning Lamp Diagnosis"](#).

#### NOTE:

SRS does not enter diagnosis mode if no malfunction is detected in user mode.

Is malfunctioning part detected?

- YES >> Refer to [SRC-94, "Diagnosis Procedure"](#).  
NO >> INSPECTION END

### Diagnosis Procedure

INFOID:000000006450401

#### WARNING:

- Before servicing, turn ignition switch OFF, disconnect battery negative terminal and wait at least 3 minutes. (To discharge backup capacitor.)
- Never use unspecified tester or other measuring device.

#### 1. CHECK HARNESS CONNECTOR

Check the harness connector.

Is the inspection result normal?

- YES >> GO TO 2.  
NO >> Replace harness connector.

#### 2. CHECK WIRING HARNESS

Check the wiring harness externals.

Is the inspection result normal?

- YES >> GO TO 3.

## B1131 SIDE MODULE RH

### < DTC/CIRCUIT DIAGNOSIS >

---

NO >> Replace wiring harness.

### 3.REPLACE AIR BAG DIAGNOSIS SENSOR UNIT

---

1. Replace air bag diagnosis sensor unit. Refer to [SR-23, "Exploded View"](#).
2. Perform DTC confirmation procedure. Refer to [SRC-94, "DTC Logic"](#).

#### Is DTC detected?

YES >> GO TO 4.

NO >> INSPECTION END

---

### 4.REPLACE FRONT SIDE AIR BAG MODULE

---

1. Replace front RH side air bag module. Refer to [SE-188, "Exploded View"](#).
2. Perform DTC confirmation procedure. Refer to [SRC-94, "DTC Logic"](#).

#### Is DTC detected?

YES >> GO TO 1.

NO >> INSPECTION END

A  
B  
C  
D  
E  
F  
G  
I  
J  
K  
L  
M  
N  
O  
P

SRC

# B1132 SIDE MODULE RH

< DTC/CIRCUIT DIAGNOSIS >

## B1132 SIDE MODULE RH

### Description

INFOID:000000006450402

For front RH side air bag module, crash is judged by main "G" sensor output signal (left side: LH satellite sensor, right side: RH satellite sensor) and safing algorithm (in air bag diagnosis sensor unit).

### OPERATION

In case of frontal collision whose acceleration exceeds the specified level, the ignition materials are ignited by electric ignition system. The system burns the gas generating materials resulting in a chemical reaction. This generates hot gases that flow into the air bag through a filter and expand the bag.

### STRUCTURE

Front RH side air bag module mainly consists of air bag and inflator that inflates air bag.

### INSTALLATION

Front RH side air bag module is installed on the side of front seat back with fixed nuts.

### DTC Logic

INFOID:000000006450403

DTC No.	Trouble diagnosis name	DTC detecting condition	Possible cause
B1132	SIDE MODULE RH [SHORT]	Front RH side air bag module circuit are shorted to each other	<ul style="list-style-type: none"><li>• Disconnection of wiring harness and short</li><li>• Malfunction in front RH side air bag module</li><li>• Malfunction in air bag diagnosis sensor unit</li></ul>

### DTC CONFIRMATION PROCEDURE

#### 1. CHECK SELF-DIAG RESULT

Ⓟ With CONSULT-III

1. Turn ignition switch ON.
2. Perform "AIR BAG" Self Diagnostic Result.

ⓧ Without CONSULT-III

1. Turn ignition switch ON.
2. Check the air bag warning lamp status. Refer to [SRC-14, "Air Bag Warning Lamp Diagnosis"](#).

#### NOTE:

SRS does not enter diagnosis mode if no malfunction is detected in user mode.

Is malfunctioning part detected?

- YES >> Refer to [SRC-96, "Diagnosis Procedure"](#).  
NO >> INSPECTION END

### Diagnosis Procedure

INFOID:000000006450404

#### WARNING:

- Before servicing, turn ignition switch OFF, disconnect battery negative terminal and wait at least 3 minutes. (To discharge backup capacitor.)
- Never use unspecified tester or other measuring device.

#### 1. CHECK HARNESS CONNECTOR

Check the harness connector.

Is the inspection result normal?

- YES >> GO TO 2.  
NO >> Replace harness connector.

#### 2. CHECK WIRING HARNESS

Check the wiring harness externals.

Is the inspection result normal?

- YES >> GO TO 3.



## B1132 SIDE MODULE RH

### < DTC/CIRCUIT DIAGNOSIS >

---

NO >> Replace wiring harness.

### 3.REPLACE AIR BAG DIAGNOSIS SENSOR UNIT

---

1. Replace air bag diagnosis sensor unit. Refer to [SR-23, "Exploded View"](#).
2. Perform DTC confirmation procedure. Refer to [SRC-96, "DTC Logic"](#).

#### Is DTC detected?

YES >> GO TO 4.

NO >> INSPECTION END

---

### 4.REPLACE FRONT SIDE AIR BAG MODULE

---

1. Replace front RH side air bag module. Refer to [SE-188, "Exploded View"](#).
2. Perform DTC confirmation procedure. Refer to [SRC-96, "DTC Logic"](#).

#### Is DTC detected?

YES >> GO TO 1.

NO >> INSPECTION END

A  
B  
C  
D  
E  
F  
G  
I  
J  
K  
L  
M  
N  
O  
P

SRC

# B1134 SIDE MODULE LH

< DTC/CIRCUIT DIAGNOSIS >

## B1134 SIDE MODULE LH

### Description

INFOID:000000006450405

For front LH side air bag module, crash is judged by main "G" sensor output signal (left side: LH satellite sensor, right side: RH satellite sensor) and safing algorithm (in air bag diagnosis sensor unit).

### OPERATION

In case of frontal collision whose acceleration exceeds the specified level, the ignition materials are ignited by electric ignition system. The system burns the gas generating materials resulting in a chemical reaction. This generates hot gases that flow into the air bag through a filter and expand the bag.

### STRUCTURE

Front LH side air bag module mainly consists of air bag and inflator that inflates air bag.

### INSTALLATION

Front LH side air bag module is installed on the side of front seat back with fixed nuts.

### DTC Logic

INFOID:000000006450406

DTC No.	Trouble diagnosis name	DTC detecting condition	Possible cause
B1134	SIDE MODULE LH [OPEN]	Front LH side air bag module circuit is open	<ul style="list-style-type: none"><li>• Disconnection of wiring harness and open</li><li>• Malfunction in front LH side air bag module</li><li>• Malfunction in air bag diagnosis sensor unit</li></ul>

### DTC CONFIRMATION PROCEDURE

#### 1. CHECK SELF-DIAG RESULT

Ⓟ With CONSULT-III

1. Turn ignition switch ON.
2. Perform "AIR BAG" Self Diagnostic Result.

ⓧ Without CONSULT-III

1. Turn ignition switch ON.
2. Check the air bag warning lamp status. Refer to [SRC-14, "Air Bag Warning Lamp Diagnosis"](#).

#### NOTE:

SRS does not enter diagnosis mode if no malfunction is detected in user mode.

Is malfunctioning part detected?

- YES >> Refer to [SRC-98, "Diagnosis Procedure"](#).  
NO >> INSPECTION END

### Diagnosis Procedure

INFOID:000000006450407

#### WARNING:

- Before servicing, turn ignition switch OFF, disconnect battery negative terminal and wait at least 3 minutes. (To discharge backup capacitor.)
- Never use unspecified tester or other measuring device.

#### 1. CHECK HARNESS CONNECTOR

Check the harness connector.

Is the inspection result normal?

- YES >> GO TO 2.  
NO >> Replace harness connector.

#### 2. CHECK WIRING HARNESS

Check the wiring harness externals.

Is the inspection result normal?

- YES >> GO TO 3.

## B1134 SIDE MODULE LH

### < DTC/CIRCUIT DIAGNOSIS >

---

NO >> Replace wiring harness.

### 3.REPLACE AIR BAG DIAGNOSIS SENSOR UNIT

---

1. Replace air bag diagnosis sensor unit. Refer to [SR-23, "Exploded View"](#).
2. Perform DTC confirmation procedure. Refer to [SRC-98, "DTC Logic"](#).

#### Is DTC detected?

YES >> GO TO 4.

NO >> INSPECTION END

---

### 4.REPLACE FRONT SIDE AIR BAG MODULE

---

1. Replace front LH side air bag module. Refer to [SE-188, "Exploded View"](#).
2. Perform DTC confirmation procedure. Refer to [SRC-98, "DTC Logic"](#).

#### Is DTC detected?

YES >> GO TO 1.

NO >> INSPECTION END

A  
B  
C  
D  
E  
F  
G  
I  
J  
K  
L  
M  
N  
O  
P

SRC

# B1135 SIDE MODULE LH

< DTC/CIRCUIT DIAGNOSIS >

## B1135 SIDE MODULE LH

### Description

INFOID:000000006450408

For front LH side air bag module, crash is judged by main "G" sensor output signal (left side: LH satellite sensor, right side: RH satellite sensor) and safing algorithm (in air bag diagnosis sensor unit).

### OPERATION

In case of frontal collision whose acceleration exceeds the specified level, the ignition materials are ignited by electric ignition system. The system burns the gas generating materials resulting in a chemical reaction. This generates hot gases that flow into the air bag through a filter and expand the bag.

### STRUCTURE

Front LH side air bag module mainly consists of air bag and inflator that inflates air bag.

### INSTALLATION

Front LH side air bag module is installed on the side of front seat back with fixed nuts.

### DTC Logic

INFOID:000000006450409

DTC No.	Trouble diagnosis name	DTC detecting condition	Possible cause
B1135	SIDE MODULE LH [VB-SHORT]	Front LH side air bag module circuit is shorted to some power supply circuit	<ul style="list-style-type: none"><li>• Disconnection of wiring harness and short</li><li>• Malfunction in front LH side air bag module</li><li>• Malfunction in air bag diagnosis sensor unit</li></ul>

### DTC CONFIRMATION PROCEDURE

#### 1.CHECK SELF-DIAG RESULT

Ⓟ With CONSULT-III

1. Turn ignition switch ON.
2. Perform "AIR BAG" Self Diagnostic Result.

ⓧ Without CONSULT-III

1. Turn ignition switch ON.
2. Check the air bag warning lamp status. Refer to [SRC-14, "Air Bag Warning Lamp Diagnosis"](#).

#### NOTE:

SRS does not enter diagnosis mode if no malfunction is detected in user mode.

Is malfunctioning part detected?

- YES >> Refer to [SRC-100, "Diagnosis Procedure"](#).  
NO >> INSPECTION END

### Diagnosis Procedure

INFOID:000000006450410

#### WARNING:

- Before servicing, turn ignition switch OFF, disconnect battery negative terminal and wait at least 3 minutes. (To discharge backup capacitor.)
- Never use unspecified tester or other measuring device.

#### 1.CHECK HARNESS CONNECTOR

Check the harness connector.

Is the inspection result normal?

- YES >> GO TO 2.  
NO >> Replace harness connector.

#### 2.CHECK WIRING HARNESS

Check the wiring harness externals.

Is the inspection result normal?

- YES >> GO TO 3.

# B1135 SIDE MODULE LH

## < DTC/CIRCUIT DIAGNOSIS >

---

NO >> Replace wiring harness.

### 3. REPLACE AIR BAG DIAGNOSIS SENSOR UNIT

---

1. Replace air bag diagnosis sensor unit. Refer to [SR-23, "Exploded View"](#).
2. Perform DTC confirmation procedure. Refer to [SRC-100, "DTC Logic"](#).

#### Is DTC detected?

YES >> GO TO 4.

NO >> INSPECTION END

---

### 4. REPLACE FRONT SIDE AIR BAG MODULE

---

1. Replace front LH side air bag module. Refer to [SE-188, "Exploded View"](#).
2. Perform DTC confirmation procedure. Refer to [SRC-100, "DTC Logic"](#).

#### Is DTC detected?

YES >> GO TO 1.

NO >> INSPECTION END

A  
B  
C  
D  
E  
F  
G  
I  
J  
K  
L  
M  
N  
O  
P

SRC

# B1136 SIDE MODULE LH

< DTC/CIRCUIT DIAGNOSIS >

## B1136 SIDE MODULE LH

### Description

INFOID:000000006450411

For front LH side air bag module, crash is judged by main "G" sensor output signal (left side: LH satellite sensor, right side: RH satellite sensor) and safing algorithm (in air bag diagnosis sensor unit).

### OPERATION

In case of frontal collision whose acceleration exceeds the specified level, the ignition materials are ignited by electric ignition system. The system burns the gas generating materials resulting in a chemical reaction. This generates hot gases that flow into the air bag through a filter and expand the bag.

### STRUCTURE

Front LH side air bag module mainly consists of air bag and inflator that inflates air bag.

### INSTALLATION

Front LH side air bag module is installed on the side of front seat back with fixed nuts.

### DTC Logic

INFOID:000000006450412

DTC No.	Trouble diagnosis name	DTC detecting condition	Possible cause
B1136	SIDE MODULE LH [GND-SHORT]	Front LH side air bag module circuit is shorted to ground	<ul style="list-style-type: none"><li>• Disconnection of wiring harness and short</li><li>• Malfunction in front LH side air bag module</li><li>• Malfunction in air bag diagnosis sensor unit</li></ul>

### DTC CONFIRMATION PROCEDURE

#### 1.CHECK SELF-DIAG RESULT

Ⓟ With CONSULT-III

1. Turn ignition switch ON.
2. Perform "AIR BAG" Self Diagnostic Result.

ⓧ Without CONSULT-III

1. Turn ignition switch ON.
2. Check the air bag warning lamp status. Refer to [SRC-14, "Air Bag Warning Lamp Diagnosis"](#).

#### NOTE:

SRS does not enter diagnosis mode if no malfunction is detected in user mode.

Is malfunctioning part detected?

- YES >> Refer to [SRC-102, "Diagnosis Procedure"](#).  
NO >> INSPECTION END

### Diagnosis Procedure

INFOID:000000006450413

#### WARNING:

- Before servicing, turn ignition switch OFF, disconnect battery negative terminal and wait at least 3 minutes. (To discharge backup capacitor.)
- Never use unspecified tester or other measuring device.

#### 1.CHECK HARNESS CONNECTOR

Check the harness connector.

Is the inspection result normal?

- YES >> GO TO 2.  
NO >> Replace harness connector.

#### 2.CHECK WIRING HARNESS

Check the wiring harness externals.

Is the inspection result normal?

- YES >> GO TO 3.

## B1136 SIDE MODULE LH

### < DTC/CIRCUIT DIAGNOSIS >

---

NO >> Replace wiring harness.

### 3.REPLACE AIR BAG DIAGNOSIS SENSOR UNIT

---

1. Replace air bag diagnosis sensor unit. Refer to [SR-23, "Exploded View"](#).
2. Perform DTC confirmation procedure. Refer to [SRC-102, "DTC Logic"](#).

#### Is DTC detected?

YES >> GO TO 4.

NO >> INSPECTION END

---

### 4.REPLACE FRONT SIDE AIR BAG MODULE

---

1. Replace front LH side air bag module. Refer to [SE-188, "Exploded View"](#).
2. Perform DTC confirmation procedure. Refer to [SRC-102, "DTC Logic"](#).

#### Is DTC detected?

YES >> GO TO 1.

NO >> INSPECTION END

A  
B  
C  
D  
E  
F  
G  
I  
J  
K  
L  
M  
N  
O  
P

SRC

# B1137 SIDE MODULE LH

< DTC/CIRCUIT DIAGNOSIS >

## B1137 SIDE MODULE LH

### Description

INFOID:000000006450414

For front LH side air bag module, crash is judged by main "G" sensor output signal (left side: LH satellite sensor, right side: RH satellite sensor) and safing algorithm (in air bag diagnosis sensor unit).

### OPERATION

In case of frontal collision whose acceleration exceeds the specified level, the ignition materials are ignited by electric ignition system. The system burns the gas generating materials resulting in a chemical reaction. This generates hot gases that flow into the air bag through a filter and expand the bag.

### STRUCTURE

Front LH side air bag module mainly consists of air bag and inflator that inflates air bag.

### INSTALLATION

Front LH side air bag module is installed on the side of front seat back with fixed nuts.

### DTC Logic

INFOID:000000006450415

DTC No.	Trouble diagnosis name	DTC detecting condition	Possible cause
B1137	SIDE MODULE LH [SHORT]	Front LH side air bag module circuit are shorted to each other	<ul style="list-style-type: none"><li>• Disconnection of wiring harness and short</li><li>• Malfunction in front LH side air bag module</li><li>• Malfunction in air bag diagnosis sensor unit</li></ul>

### DTC CONFIRMATION PROCEDURE

#### 1.CHECK SELF-DIAG RESULT

Ⓟ With CONSULT-III

1. Turn ignition switch ON.
2. Perform "AIR BAG" Self Diagnostic Result.

ⓧ Without CONSULT-III

1. Turn ignition switch ON.
2. Check the air bag warning lamp status. Refer to [SRC-14, "Air Bag Warning Lamp Diagnosis"](#).

#### NOTE:

SRS does not enter diagnosis mode if no malfunction is detected in user mode.

Is malfunctioning part detected?

- YES >> Refer to [SRC-104, "Diagnosis Procedure"](#).  
NO >> INSPECTION END

### Diagnosis Procedure

INFOID:000000006450416

#### WARNING:

- Before servicing, turn ignition switch OFF, disconnect battery negative terminal and wait at least 3 minutes. (To discharge backup capacitor.)
- Never use un specified tester or other measuring device.

#### 1.CHECK HARNESS CONNECTOR

Check the harness connector.

Is the inspection result normal?

- YES >> GO TO 2.  
NO >> Replace harness connector.

#### 2.CHECK WIRING HARNESS

Check the wiring harness externals.

Is the inspection result normal?

- YES >> GO TO 3.



## B1137 SIDE MODULE LH

### < DTC/CIRCUIT DIAGNOSIS >

---

NO >> Replace wiring harness.

### 3.REPLACE AIR BAG DIAGNOSIS SENSOR UNIT

---

1. Replace air bag diagnosis sensor unit. Refer to [SR-23, "Exploded View"](#).
2. Perform DTC confirmation procedure. Refer to [SRC-104, "DTC Logic"](#).

#### Is DTC detected?

YES >> GO TO 4.

NO >> INSPECTION END

---

### 4.REPLACE FRONT SIDE AIR BAG MODULE

---

1. Replace front LH side air bag module. Refer to [SE-188, "Exploded View"](#).
2. Perform DTC confirmation procedure. Refer to [SRC-104, "DTC Logic"](#).

#### Is DTC detected?

YES >> GO TO 1.

NO >> INSPECTION END

A  
B  
C  
D  
E  
F  
G  
I  
J  
K  
L  
M  
N  
O  
P

SRC

# B1138, B1139, B1140, B1141, B1142, B1143 DIAGNOSIS SENSOR UNIT

< DTC/CIRCUIT DIAGNOSIS >

## B1138, B1139, B1140, B1141, B1142, B1143 DIAGNOSIS SENSOR UNIT

### Description

INFOID:000000006450417

Checks the entire SRS and displays the malfunction either by illuminating or blinking the air bag warning lamp on the combination meter. Malfunctioning part can be detected by on board self-diagnosis system and CONSULT-III.

### OPERATION

It detects a shock that exceeds a specified level and monitors whether the driver and passenger air bags, front side air bag, side curtain air bag and pre-tensioner seat belts operate normally.

### STRUCTURE

It contains the "G" sensors for both frontal and side collisions and spare battery function in case of main battery damage in collision.

### INSTALLATION

Air bag diagnosis sensor unit is installed under the center console with fixed bolts.

### DTC Logic

INFOID:000000006450418

DTC No.	Trouble diagnosis name	DTC detecting condition	Possible cause
B1138 B1139 B1140 B1141 B1142 B1143	CONTROL UNIT	Air bag diagnosis sensor unit is malfunctioning or out of the specification	<ul style="list-style-type: none"><li>Malfunction in air bag diagnosis sensor unit</li><li>Configuration in air bag diagnosis sensor unit does not match the vehicle specification</li></ul>

### DTC CONFIRMATION PROCEDURE

#### 1. CHECK SELF-DIAG RESULT

With CONSULT-III

- Turn ignition switch ON.
- Perform "AIR BAG" Self Diagnostic Result.

Without CONSULT-III

- Turn ignition switch ON.
- Check the air bag warning lamp status. Refer to [SRC-14, "Air Bag Warning Lamp Diagnosis"](#).

#### NOTE:

SRS does not enter diagnosis mode if no malfunction is detected in user mode.

Is malfunctioning part detected?

YES >> Refer to [SRC-106, "Diagnosis Procedure"](#).

NO >> INSPECTION END

### Diagnosis Procedure

INFOID:000000006450419

#### WARNING:

- Before servicing, turn ignition switch OFF, disconnect battery negative terminal and wait at least 3 minutes. (To discharge backup capacitor.)
- Never use unspecified tester or other measuring device.

#### 1. CHECK HARNESS CONNECTOR

Check the harness connector.

Is the inspection result normal?

YES >> GO TO 2.

NO >> Replace harness connectors.

#### 2. CHECK WIRING HARNESS

Check the wiring harness externals.

Is the inspection result normal?

# B1138, B1139, B1140, B1141, B1142, B1143 DIAGNOSIS SENSOR UNIT

## < DTC/CIRCUIT DIAGNOSIS >

---

YES >> GO TO 3.

NO >> Replace wiring harness.

### 3. REPLACE AIR BAG DIAGNOSIS SENSOR UNIT

---

1. Replace air bag diagnosis sensor unit. Refer to [SR-23. "Exploded View"](#).

2. Perform DTC confirmation procedure. Refer to [SRC-106. "DTC Logic"](#).

#### Is DTC detected?

YES >> GO TO 1.

NO >> INSPECTION END

A

B

C

D

E

F

G

SRC

I

J

K

L

M

N

O

P

# B1145 CURTAIN MODULE RH

< DTC/CIRCUIT DIAGNOSIS >

## B1145 CURTAIN MODULE RH

### Description

INFOID:000000006450420

For RH side curtain air bag module, crash is judged by main "G" sensor output signal (left side: LH satellite sensor, right side: RH satellite sensor) and safing algorithm (in air bag diagnosis sensor unit).

### OPERATION

In case of frontal collision whose acceleration exceeds the specified level, the ignition materials are ignited by electric ignition system. The system burns the gas generating materials resulting in a chemical reaction. This generates hot gases that flow into the air bag through a filter and expand the bag.

### STRUCTURE

RH side curtain air bag module mainly consists of air bag and inflator that inflates air bag.

### INSTALLATION

RH side curtain air bag module is installed on the roof side with fixed bolts.

### DTC Logic

INFOID:000000006450421

DTC No.	Trouble diagnosis name	DTC detecting condition	Possible cause
B1145	CURTAIN MODULE RH [OPEN]	RH side curtain air bag module circuit is open	<ul style="list-style-type: none"><li>• Disconnection of wiring harness and open</li><li>• Malfunction in RH side curtain air bag module</li><li>• Malfunction in air bag diagnosis sensor unit</li></ul>

### DTC CONFIRMATION PROCEDURE

#### 1. CHECK SELF-DIAG RESULT

With CONSULT-III

1. Turn ignition switch ON.
2. Perform "AIR BAG" Self Diagnostic Result.

Without CONSULT-III

1. Turn ignition switch ON.
2. Check the air bag warning lamp status. Refer to [SRC-14, "Air Bag Warning Lamp Diagnosis"](#).

#### NOTE:

SRS does not enter diagnosis mode if no malfunction is detected in user mode.

Is malfunctioning part detected?

- YES >> Refer to [SRC-108, "Diagnosis Procedure"](#).  
NO >> INSPECTION END

### Diagnosis Procedure

INFOID:000000006450422

#### WARNING:

- Before servicing, turn ignition switch OFF, disconnect battery negative terminal and wait at least 3 minutes. (To discharge backup capacitor.)
- Never use unspecified tester or other measuring device.

#### 1. CHECK HARNESS CONNECTOR

Check the harness connector.

Is the inspection result normal?

- YES >> GO TO 2.  
NO >> Replace harness connector.

#### 2. CHECK WIRING HARNESS

Check the wiring harness externals.

Is the inspection result normal?

- YES >> GO TO 3.

## B1145 CURTAIN MODULE RH

### < DTC/CIRCUIT DIAGNOSIS >

---

NO >> Replace wiring harness.

### 3.REPLACE AIR BAG DIAGNOSIS SENSOR UNIT

---

1. Replace air bag diagnosis sensor unit. Refer to [SR-23, "Exploded View"](#).
2. Perform DTC confirmation procedure. Refer to [SRC-108, "DTC Logic"](#).

#### Is DTC detected?

YES >> GO TO 4.

NO >> INSPECTION END

---

### 4.REPLACE SIDE CURTAIN AIR BAG MODULE

---

1. Replace RH side curtain air bag module. Refer to [SR-19, "Exploded View"](#)
2. Perform DTC confirmation procedure. Refer to [SRC-108, "DTC Logic"](#).

#### Is DTC detected?

YES >> GO TO 1.

NO >> INSPECTION END

A  
B  
C  
D  
E  
F  
G  
I  
J  
K  
L  
M  
N  
O  
P

SRC

# B1146 CURTAIN MODULE RH

< DTC/CIRCUIT DIAGNOSIS >

## B1146 CURTAIN MODULE RH

### Description

INFOID:000000006450423

For RH side curtain air bag module, crash is judged by main "G" sensor output signal (left side: LH satellite sensor, right side: RH satellite sensor) and safing algorithm (in air bag diagnosis sensor unit).

### OPERATION

In case of frontal collision whose acceleration exceeds the specified level, the ignition materials are ignited by electric ignition system. The system burns the gas generating materials resulting in a chemical reaction. This generates hot gases that flow into the air bag through a filter and expand the bag.

### STRUCTURE

RH side curtain air bag module mainly consists of air bag and inflator that inflates air bag.

### INSTALLATION

RH side curtain air bag module is installed on the roof side with fixed bolts.

### DTC Logic

INFOID:000000006450424

DTC No.	Trouble diagnosis name	DTC detecting condition	Possible cause
B1146	CURTAIN MODULE RH [VB-SHORT]	RH side curtain air bag module circuit is shorted to some power supply circuit	<ul style="list-style-type: none"><li>• Disconnection of wiring harness and short</li><li>• Malfunction in RH side curtain air bag module</li><li>• Malfunction in air bag diagnosis sensor unit</li></ul>

### DTC CONFIRMATION PROCEDURE

#### 1. CHECK SELF-DIAG RESULT

Ⓟ With CONSULT-III

1. Turn ignition switch ON.
2. Perform "AIR BAG" Self Diagnostic Result.

ⓧ Without CONSULT-III

1. Turn ignition switch ON.
2. Check the air bag warning lamp status. Refer to [SRC-14, "Air Bag Warning Lamp Diagnosis"](#).

#### NOTE:

SRS does not enter diagnosis mode if no malfunction is detected in user mode.

Is malfunctioning part detected?

- YES >> Refer to [SRC-110, "Diagnosis Procedure"](#).  
NO >> INSPECTION END

### Diagnosis Procedure

INFOID:000000006450425

#### WARNING:

- Before servicing, turn ignition switch OFF, disconnect battery negative terminal and wait at least 3 minutes. (To discharge backup capacitor.)
- Never use unspecified tester or other measuring device.

#### 1. CHECK HARNESS CONNECTOR

Check the harness connector.

Is the inspection result normal?

- YES >> GO TO 2.  
NO >> Replace harness connector.

#### 2. CHECK WIRING HARNESS

Check the wiring harness externals.

Is the inspection result normal?

- YES >> GO TO 3.

# B1146 CURTAIN MODULE RH

## < DTC/CIRCUIT DIAGNOSIS >

---

NO >> Replace wiring harness.

### 3.REPLACE AIR BAG DIAGNOSIS SENSOR UNIT

---

1. Replace air bag diagnosis sensor unit. Refer to [SR-23, "Exploded View"](#).
2. Perform DTC confirmation procedure. Refer to [SRC-110, "DTC Logic"](#).

#### Is DTC detected?

YES >> GO TO 4.

NO >> INSPECTION END

---

### 4.REPLACE SIDE CURTAIN AIR BAG MODULE

---

1. Replace RH side curtain air bag module. Refer to [SR-19, "Exploded View"](#)
2. Perform DTC confirmation procedure. Refer to [SRC-110, "DTC Logic"](#).

#### Is DTC detected?

YES >> GO TO 1.

NO >> INSPECTION END

A  
B  
C  
D  
E  
F  
G  
I  
J  
K  
L  
M  
N  
O  
P

SRC

# B1147 CURTAIN MODULE RH

< DTC/CIRCUIT DIAGNOSIS >

## B1147 CURTAIN MODULE RH

### Description

INFOID:000000006450426

For RH side curtain air bag module, crash is judged by main "G" sensor output signal (left side: LH satellite sensor, right side: RH satellite sensor) and safing algorithm (in air bag diagnosis sensor unit).

### OPERATION

In case of frontal collision whose acceleration exceeds the specified level, the ignition materials are ignited by electric ignition system. The system burns the gas generating materials resulting in a chemical reaction. This generates hot gases that flow into the air bag through a filter and expand the bag.

### STRUCTURE

RH side curtain air bag module mainly consists of air bag and inflator that inflates air bag.

### INSTALLATION

RH side curtain air bag module is installed on the roof side with fixed bolts.

### DTC Logic

INFOID:000000006450427

DTC No.	Trouble diagnosis name	DTC detecting condition	Possible cause
B1147	CURTAIN MODULE RH [GND-SHORT]	RH side curtain air bag module circuit is shorted to ground	<ul style="list-style-type: none"><li>• Disconnection of wiring harness and short</li><li>• Malfunction in RH side curtain air bag module</li><li>• Malfunction in air bag diagnosis sensor unit</li></ul>

### DTC CONFIRMATION PROCEDURE

#### 1. CHECK SELF-DIAG RESULT

Ⓟ With CONSULT-III

1. Turn ignition switch ON.
2. Perform "AIR BAG" Self Diagnostic Result.

ⓧ Without CONSULT-III

1. Turn ignition switch ON.
2. Check the air bag warning lamp status. Refer to [SRC-14, "Air Bag Warning Lamp Diagnosis"](#).

#### NOTE:

SRS does not enter diagnosis mode if no malfunction is detected in user mode.

Is malfunctioning part detected?

- YES >> Refer to [SRC-112, "Diagnosis Procedure"](#).  
NO >> INSPECTION END

### Diagnosis Procedure

INFOID:000000006450428

#### WARNING:

- Before servicing, turn ignition switch OFF, disconnect battery negative terminal and wait at least 3 minutes. (To discharge backup capacitor.)
- Never use unspecified tester or other measuring device.

#### 1. CHECK HARNESS CONNECTOR

Check the harness connector.

Is the inspection result normal?

- YES >> GO TO 2.  
NO >> Replace harness connector.

#### 2. CHECK WIRING HARNESS

Check the wiring harness externals.

Is the inspection result normal?

- YES >> GO TO 3.



## B1147 CURTAIN MODULE RH

### < DTC/CIRCUIT DIAGNOSIS >

---

NO >> Replace wiring harness.

### 3.REPLACE AIR BAG DIAGNOSIS SENSOR UNIT

---

1. Replace air bag diagnosis sensor unit. Refer to [SR-23, "Exploded View"](#).
2. Perform DTC confirmation procedure. Refer to [SRC-112, "DTC Logic"](#).

#### Is DTC detected?

YES >> GO TO 4.

NO >> INSPECTION END

---

### 4.REPLACE SIDE CURTAIN AIR BAG MODULE

---

1. Replace RH side curtain air bag module. Refer to [SR-19, "Exploded View"](#).
2. Perform DTC confirmation procedure. Refer to [SRC-112, "DTC Logic"](#).

#### Is DTC detected?

YES >> GO TO 1.

NO >> INSPECTION END

A  
B  
C  
D  
E  
F  
G  
I  
J  
K  
L  
M  
N  
O  
P

SRC

# B1148 CURTAIN MODULE RH

< DTC/CIRCUIT DIAGNOSIS >

## B1148 CURTAIN MODULE RH

### Description

INFOID:000000006450429

For RH side curtain air bag module, crash is judged by main "G" sensor output signal (left side: LH satellite sensor, right side: RH satellite sensor) and safing algorithm (in air bag diagnosis sensor unit).

### OPERATION

In case of frontal collision whose acceleration exceeds the specified level, the ignition materials are ignited by electric ignition system. The system burns the gas generating materials resulting in a chemical reaction. This generates hot gases that flow into the air bag through a filter and expand the bag.

### STRUCTURE

RH side curtain air bag module mainly consists of air bag and inflator that inflates air bag.

### INSTALLATION

RH side curtain air bag module is installed on the roof side with fixed bolts.

### DTC Logic

INFOID:000000006450430

DTC No.	Trouble diagnosis name	DTC detecting condition	Possible cause
B1148	CURTAIN MODULE RH [SHORT]	RH side curtain air bag module circuit are shorted to each other	<ul style="list-style-type: none"><li>• Disconnection of wiring harness and short</li><li>• Malfunction in RH side curtain air bag module</li><li>• Malfunction in air bag diagnosis sensor unit</li></ul>

### DTC CONFIRMATION PROCEDURE

#### 1. CHECK SELF-DIAG RESULT

With CONSULT-III

1. Turn ignition switch ON.
2. Perform "AIR BAG" Self Diagnostic Result.

Without CONSULT-III

1. Turn ignition switch ON.
2. Check the air bag warning lamp status. Refer to [SRC-14, "Air Bag Warning Lamp Diagnosis"](#).

#### NOTE:

SRS does not enter diagnosis mode if no malfunction is detected in user mode.

Is malfunctioning part detected?

- YES >> Refer to [SRC-114, "Diagnosis Procedure"](#).  
NO >> INSPECTION END

### Diagnosis Procedure

INFOID:000000006450431

#### WARNING:

- Before servicing, turn ignition switch OFF, disconnect battery negative terminal and wait at least 3 minutes. (To discharge backup capacitor.)
- Never use unspecified tester or other measuring device.

#### 1. CHECK HARNESS CONNECTOR

Check the harness connector.

Is the inspection result normal?

- YES >> GO TO 2.  
NO >> Replace harness connector.

#### 2. CHECK WIRING HARNESS

Check the wiring harness externals.

Is the inspection result normal?

- YES >> GO TO 3.

# B1148 CURTAIN MODULE RH

## < DTC/CIRCUIT DIAGNOSIS >

---

NO >> Replace wiring harness.

### 3.REPLACE AIR BAG DIAGNOSIS SENSOR UNIT

---

1. Replace air bag diagnosis sensor unit. Refer to [SR-23, "Exploded View"](#).
2. Perform DTC confirmation procedure. Refer to [SRC-114, "DTC Logic"](#).

#### Is DTC detected?

YES >> GO TO 4.

NO >> INSPECTION END

---

### 4.REPLACE SIDE CURTAIN AIR BAG MODULE

---

1. Replace RH side curtain air bag module. Refer to [SR-19, "Exploded View"](#).
2. Perform DTC confirmation procedure. Refer to [SRC-114, "DTC Logic"](#).

#### Is DTC detected?

YES >> GO TO 1.

NO >> INSPECTION END

A  
B  
C  
D  
E  
F  
G  
I  
J  
K  
L  
M  
N  
O  
P

SRC

# B1150 CURTAIN MODULE LH

< DTC/CIRCUIT DIAGNOSIS >

## B1150 CURTAIN MODULE LH

### Description

INFOID:000000006450432

For RH side curtain air bag module, crash is judged by main "G" sensor output signal (left side: LH satellite sensor, right side: RH satellite sensor) and safing algorithm (in air bag diagnosis sensor unit).

### OPERATION

In case of frontal collision whose acceleration exceeds the specified level, the ignition materials are ignited by electric ignition system. The system burns the gas generating materials resulting in a chemical reaction. This generates hot gases that flow into the air bag through a filter and expand the bag.

### STRUCTURE

LH side curtain air bag module mainly consists of air bag and inflator that inflates air bag.

### INSTALLATION

LH side curtain air bag module is installed on the roof side with fixed bolts.

### DTC Logic

INFOID:000000006450433

DTC No.	Trouble diagnosis name	DTC detecting condition	Possible cause
B1150	CURTAIN MODULE LH [OPEN]	LH side curtain air bag module circuit is open	<ul style="list-style-type: none"><li>• Disconnection of wiring harness and open</li><li>• Malfunction in LH side curtain air bag module</li><li>• Malfunction in air bag diagnosis sensor unit</li></ul>

### DTC CONFIRMATION PROCEDURE

#### 1. CHECK SELF-DIAG RESULT

Ⓟ With CONSULT-III

1. Turn ignition switch ON.
2. Perform "AIR BAG" Self Diagnostic Result.

ⓧ Without CONSULT-III

1. Turn ignition switch ON.
2. Check the air bag warning lamp status. Refer to [SRC-14, "Air Bag Warning Lamp Diagnosis"](#).

#### NOTE:

SRS does not enter diagnosis mode if no malfunction is detected in user mode.

Is malfunctioning part detected?

- YES >> Refer to [SRC-116, "Diagnosis Procedure"](#).  
NO >> INSPECTION END

### Diagnosis Procedure

INFOID:000000006450434

#### WARNING:

- Before servicing, turn ignition switch OFF, disconnect battery negative terminal and wait at least 3 minutes. (To discharge backup capacitor.)
- Never use unspecified tester or other measuring device.

#### 1. CHECK HARNESS CONNECTOR

Check the harness connector.

Is the inspection result normal?

- YES >> GO TO 2.  
NO >> Replace harness connector.

#### 2. CHECK WIRING HARNESS

Check the wiring harness externals.

Is the inspection result normal?

- YES >> GO TO 3.

## B1150 CURTAIN MODULE LH

### < DTC/CIRCUIT DIAGNOSIS >

---

NO >> Replace wiring harness.

### 3.REPLACE AIR BAG DIAGNOSIS SENSOR UNIT

---

1. Replace air bag diagnosis sensor unit. Refer to [SR-23, "Exploded View"](#).
2. Perform DTC confirmation procedure. Refer to [SRC-116, "DTC Logic"](#).

#### Is DTC detected?

YES >> GO TO 4.

NO >> INSPECTION END

---

### 4.REPLACE SIDE CURTAIN AIR BAG MODULE

---

1. Replace LH side curtain air bag module. Refer to [SR-19, "Exploded View"](#).
2. Perform DTC confirmation procedure. Refer to [SRC-116, "DTC Logic"](#).

#### Is DTC detected?

YES >> GO TO 1.

NO >> INSPECTION END

A  
B  
C  
D  
E  
F  
G  
I  
J  
K  
L  
M  
N  
O  
P

SRC

# B1151 CURTAIN MODULE LH

< DTC/CIRCUIT DIAGNOSIS >

## B1151 CURTAIN MODULE LH

### Description

INFOID:000000006450435

For RH side curtain air bag module, crash is judged by main "G" sensor output signal (left side: LH satellite sensor, right side: RH satellite sensor) and safing algorithm (in air bag diagnosis sensor unit).

### OPERATION

In case of frontal collision whose acceleration exceeds the specified level, the ignition materials are ignited by electric ignition system. The system burns the gas generating materials resulting in a chemical reaction. This generates hot gases that flow into the air bag through a filter and expand the bag.

### STRUCTURE

LH side curtain air bag module mainly consists of air bag and inflator that inflates air bag.

### INSTALLATION

LH side curtain air bag module is installed on the roof side with fixed bolts.

### DTC Logic

INFOID:000000006450436

DTC No.	Trouble diagnosis name	DTC detecting condition	Possible cause
B1151	CURTAIN MODULE LH [VB-SHORT]	LH side curtain air bag module circuit is shorted to some power supply circuit	<ul style="list-style-type: none"><li>• Disconnection of wiring harness and short</li><li>• Malfunction in LH side curtain air bag module</li><li>• Malfunction in air bag diagnosis sensor unit</li></ul>

### DTC CONFIRMATION PROCEDURE

#### 1. CHECK SELF-DIAG RESULT

With CONSULT-III

1. Turn ignition switch ON.
2. Perform "AIR BAG" Self Diagnostic Result.

Without CONSULT-III

1. Turn ignition switch ON.
2. Check the air bag warning lamp status. Refer to [SRC-14, "Air Bag Warning Lamp Diagnosis"](#).

#### NOTE:

SRS does not enter diagnosis mode if no malfunction is detected in user mode.

Is malfunctioning part detected?

- YES >> Refer to [SRC-118, "Diagnosis Procedure"](#).  
NO >> INSPECTION END

### Diagnosis Procedure

INFOID:000000006450437

#### WARNING:

- Before servicing, turn ignition switch OFF, disconnect battery negative terminal and wait at least 3 minutes. (To discharge backup capacitor.)
- Never use unspecified tester or other measuring device.

#### 1. CHECK HARNESS CONNECTOR

Check the harness connector.

Is the inspection result normal?

- YES >> GO TO 2.  
NO >> Replace harness connector.

#### 2. CHECK WIRING HARNESS

Check the wiring harness externals.

Is the inspection result normal?

- YES >> GO TO 3.

# B1151 CURTAIN MODULE LH

## < DTC/CIRCUIT DIAGNOSIS >

---

NO >> Replace wiring harness.

### 3.REPLACE AIR BAG DIAGNOSIS SENSOR UNIT

---

1. Replace air bag diagnosis sensor unit. Refer to [SR-23, "Exploded View"](#).
2. Perform DTC confirmation procedure. Refer to [SRC-118, "DTC Logic"](#).

#### Is DTC detected?

YES >> GO TO 4.

NO >> INSPECTION END

---

### 4.REPLACE SIDE CURTAIN AIR BAG MODULE

---

1. Replace LH side curtain air bag module. Refer to [SR-19, "Exploded View"](#).
2. Perform DTC confirmation procedure. Refer to [SRC-118, "DTC Logic"](#).

#### Is DTC detected?

YES >> GO TO 1.

NO >> INSPECTION END

A  
B  
C  
D  
E  
F  
G  
I  
J  
K  
L  
M  
N  
O  
P

SRC

# B1152 CURTAIN MODULE LH

< DTC/CIRCUIT DIAGNOSIS >

## B1152 CURTAIN MODULE LH

### Description

INFOID:000000006450438

For RH side curtain air bag module, crash is judged by main "G" sensor output signal (left side: LH satellite sensor, right side: RH satellite sensor) and safing algorithm (in air bag diagnosis sensor unit).

### OPERATION

In case of frontal collision whose acceleration exceeds the specified level, the ignition materials are ignited by electric ignition system. The system burns the gas generating materials resulting in a chemical reaction. This generates hot gases that flow into the air bag through a filter and expand the bag.

### STRUCTURE

LH side curtain air bag module mainly consists of air bag and inflator that inflates air bag.

### INSTALLATION

LH side curtain air bag module is installed on the roof side with fixed bolts.

### DTC Logic

INFOID:000000006450439

DTC No.	Trouble diagnosis name	DTC detecting condition	Possible cause
B1152	CURTAIN MODULE LH [GND-SHORT]	LH side curtain air bag module circuit is shorted to ground	<ul style="list-style-type: none"><li>• Disconnection of wiring harness and short</li><li>• Malfunction in LH side curtain air bag module</li><li>• Malfunction in air bag diagnosis sensor unit</li></ul>

### DTC CONFIRMATION PROCEDURE

#### 1. CHECK SELF-DIAG RESULT

With CONSULT-III

1. Turn ignition switch ON.
2. Perform "AIR BAG" Self Diagnostic Result.

Without CONSULT-III

1. Turn ignition switch ON.
2. Check the air bag warning lamp status. Refer to [SRC-14, "Air Bag Warning Lamp Diagnosis"](#).

#### NOTE:

SRS does not enter diagnosis mode if no malfunction is detected in user mode.

Is malfunctioning part detected?

- YES >> Refer to [SRC-120, "Diagnosis Procedure"](#).  
NO >> INSPECTION END

### Diagnosis Procedure

INFOID:000000006450440

#### WARNING:

- Before servicing, turn ignition switch OFF, disconnect battery negative terminal and wait at least 3 minutes. (To discharge backup capacitor.)
- Never use unspecified tester or other measuring device.

#### 1. CHECK HARNESS CONNECTOR

Check the harness connector.

Is the inspection result normal?

- YES >> GO TO 2.  
NO >> Replace harness connector.

#### 2. CHECK WIRING HARNESS

Check the wiring harness externals.

Is the inspection result normal?

- YES >> GO TO 3.



## B1152 CURTAIN MODULE LH

### < DTC/CIRCUIT DIAGNOSIS >

---

NO >> Replace wiring harness.

### 3.REPLACE AIR BAG DIAGNOSIS SENSOR UNIT

---

1. Replace air bag diagnosis sensor unit. Refer to [SR-23, "Exploded View"](#).
2. Perform DTC confirmation procedure. Refer to [SRC-120, "DTC Logic"](#).

#### Is DTC detected?

YES >> GO TO 4.

NO >> INSPECTION END

---

### 4.REPLACE SIDE CURTAIN AIR BAG MODULE

---

1. Replace LH side curtain air bag module. Refer to [SR-19, "Exploded View"](#).
2. Perform DTC confirmation procedure. Refer to [SRC-120, "DTC Logic"](#).

#### Is DTC detected?

YES >> GO TO 1.

NO >> INSPECTION END

A  
B  
C  
D  
E  
F  
G  
I  
J  
K  
L  
M  
N  
O  
P

SRC

# B1153 CURTAIN MODULE LH

< DTC/CIRCUIT DIAGNOSIS >

## B1153 CURTAIN MODULE LH

### Description

INFOID:000000006450441

For RH side curtain air bag module, crash is judged by main "G" sensor output signal (left side: LH satellite sensor, right side: RH satellite sensor) and safing algorithm (in air bag diagnosis sensor unit).

### OPERATION

In case of frontal collision whose acceleration exceeds the specified level, the ignition materials are ignited by electric ignition system. The system burns the gas generating materials resulting in a chemical reaction. This generates hot gases that flow into the air bag through a filter and expand the bag.

### STRUCTURE

LH side curtain air bag module mainly consists of air bag and inflator that inflates air bag.

### INSTALLATION

LH side curtain air bag module is installed on the roof side with fixed bolts.

### DTC Logic

INFOID:000000006450442

DTC No.	Trouble diagnosis name	DTC detecting condition	Possible cause
B1153	CURTAIN MODULE LH [SHORT]	LH side curtain air bag module circuit are shorted to each other	<ul style="list-style-type: none"><li>• Disconnection of wiring harness and short</li><li>• Malfunction in LH side curtain air bag module</li><li>• Malfunction in air bag diagnosis sensor unit</li></ul>

### DTC CONFIRMATION PROCEDURE

#### 1. CHECK SELF-DIAG RESULT

With CONSULT-III

1. Turn ignition switch ON.
2. Perform "AIR BAG" Self Diagnostic Result.

Without CONSULT-III

1. Turn ignition switch ON.
2. Check the air bag warning lamp status. Refer to [SRC-14, "Air Bag Warning Lamp Diagnosis"](#).

#### NOTE:

SRS does not enter diagnosis mode if no malfunction is detected in user mode.

Is malfunctioning part detected?

- YES >> Refer to [SRC-122, "Diagnosis Procedure"](#).  
NO >> INSPECTION END

### Diagnosis Procedure

INFOID:000000006450443

#### WARNING:

- Before servicing, turn ignition switch OFF, disconnect battery negative terminal and wait at least 3 minutes. (To discharge backup capacitor.)
- Never use unspecified tester or other measuring device.

#### 1. CHECK HARNESS CONNECTOR

Check the harness connector.

Is the inspection result normal?

- YES >> GO TO 2.  
NO >> Replace harness connector.

#### 2. CHECK WIRING HARNESS

Check the wiring harness externals.

Is the inspection result normal?

- YES >> GO TO 3.

# B1153 CURTAIN MODULE LH

## < DTC/CIRCUIT DIAGNOSIS >

---

NO >> Replace wiring harness.

### 3.REPLACE AIR BAG DIAGNOSIS SENSOR UNIT

---

1. Replace air bag diagnosis sensor unit. Refer to [SR-23, "Exploded View"](#).
2. Perform DTC confirmation procedure. Refer to [SRC-122, "DTC Logic"](#).

#### Is DTC detected?

YES >> GO TO 4.

NO >> INSPECTION END

---

### 4.REPLACE SIDE CURTAIN AIR BAG MODULE

---

1. Replace LH side curtain air bag module. Refer to [SR-19, "Exploded View"](#).
2. Perform DTC confirmation procedure. Refer to [SRC-122, "DTC Logic"](#).

#### Is DTC detected?

YES >> GO TO 1.

NO >> INSPECTION END

A  
B  
C  
D  
E  
F  
G  
I  
J  
K  
L  
M  
N  
O  
P

SRC

# B1202, B1203, B1204, B1205, B1206, B1207 DIAGNOSIS SENSOR UNIT

< DTC/CIRCUIT DIAGNOSIS >

## B1202, B1203, B1204, B1205, B1206, B1207 DIAGNOSIS SENSOR UNIT

### Description

INFOID:000000006450444

Checks the entire SRS and displays the malfunction either by illuminating or blinking the air bag warning lamp on the combination meter. Malfunctioning part can be detected by on board self-diagnosis system and CONSULT-III.

### OPERATION

It detects a shock that exceeds a specified level and monitors whether the driver and passenger air bags, front side air bag, side curtain air bag and pre-tensioner seat belts operate normally.

### STRUCTURE

It contains the "G" sensors for both frontal and side collisions and spare battery function in case of main battery damage in collision.

### INSTALLATION

Air bag diagnosis sensor unit is installed under the center console with fixed bolts.

### DTC Logic

INFOID:000000006450445

DTC No.	Trouble diagnosis name	DTC detecting condition	Possible cause
B1202 B1203 B1204 B1205 B1206 B1207	CONTROL UNIT	Air bag diagnosis sensor unit is malfunctioning or out of the specification	<ul style="list-style-type: none"><li>Malfunction in air bag diagnosis sensor unit</li><li>Configuration in air bag diagnosis sensor unit does not match the vehicle specification</li></ul>

### DTC CONFIRMATION PROCEDURE

#### 1. CHECK SELF-DIAG RESULT

With CONSULT-III

- Turn ignition switch ON.
- Perform "AIR BAG" Self Diagnostic Result.

Without CONSULT-III

- Turn ignition switch ON.
- Check the air bag warning lamp status. Refer to [SRC-14, "Air Bag Warning Lamp Diagnosis"](#).

#### NOTE:

SRS does not enter diagnosis mode if no malfunction is detected in user mode.

Is malfunctioning part detected?

YES >> Refer to [SRC-124, "Diagnosis Procedure"](#).

NO >> INSPECTION END

### Diagnosis Procedure

INFOID:000000006450446

#### WARNING:

- Before servicing, turn ignition switch OFF, disconnect battery negative terminal and wait at least 3 minutes. (To discharge backup capacitor.)
- Never use unspecified tester or other measuring device.

#### 1. CHECK HARNESS CONNECTOR

Check the harness connector.

Is the inspection result normal?

YES >> GO TO 2.

NO >> Replace harness connectors.

#### 2. CHECK WIRING HARNESS

Check the wiring harness externals.

Is the inspection result normal?

# B1202, B1203, B1204, B1205, B1206, B1207 DIAGNOSIS SENSOR UNIT

## < DTC/CIRCUIT DIAGNOSIS >

---

YES >> GO TO 3.

NO >> Replace wiring harness.

### 3. REPLACE AIR BAG DIAGNOSIS SENSOR UNIT

---

1. Replace air bag diagnosis sensor unit. Refer to [SR-23. "Exploded View"](#).

2. Perform DTC confirmation procedure. Refer to [SRC-124. "DTC Logic"](#).

#### Is DTC detected?

YES >> GO TO 1.

NO >> INSPECTION END

A

B

C

D

E

F

G

SRC

I

J

K

L

M

N

O

P

# B1209 FRONTAL COLLISION DETECTION

< DTC/CIRCUIT DIAGNOSIS >

## B1209 FRONTAL COLLISION DETECTION

### Description

INFOID:000000006450447

#### DTC B1209 FRONTAL COLLISION DETECTION

When crash zone sensor detects component damage resulting from a front collision, the system blinks or illuminates the air bag warning lamp to inform the driver. Malfunctioning can be detected by CONSULT-III.

#### OPERATION

The air bags and seat belt pre-tensioners for driver and front passenger are activated by the air bag diagnosis sensor unit signal transmitted at the time of the frontal collision.

#### STRUCTURE

It consists of crash zone sensor, air bag diagnosis sensor unit, air bags and seat belt pre-tensioners for driver and front passenger.

#### INSTALLATION

Refer to [SR-11, "Exploded View"](#) (Driver air bag module), [SR-17, "Exploded View"](#) (Front passenger air bag module), [SR-21, "Exploded View"](#) (Crash zone sensor), [SR-23, "Exploded View"](#) (Air bag diagnosis sensor unit), [SB-6, "SEAT BELT RETRACTOR : Exploded View"](#) (Front LH/RH seat belt pre-tensioner).

### DTC Logic

INFOID:000000006450448

DTC No.	Trouble diagnosis name	DTC detecting condition	Possible cause
B1209	FRONTAL COLLISION DETECTION	Front seat belt pre-tensioner, front air bag is deployed	—

### DTC CONFIRMATION PROCEDURE

#### 1. CHECK SELF-DIAG RESULT

With CONSULT-III

1. Turn ignition switch ON.
2. Perform "AIR BAG" Self Diagnostic Result.

Without CONSULT-III

1. Turn ignition switch ON.
2. Check the air bag warning lamp status. Refer to [SRC-14, "Air Bag Warning Lamp Diagnosis"](#).

#### NOTE:

SRS does not enter diagnosis mode if no malfunction is detected in user mode.

Is malfunctioning part detected?

- YES >> Refer to [SRC-126, "Diagnosis Procedure"](#).  
NO >> INSPECTION END

### Diagnosis Procedure

INFOID:000000006450449

#### WARNING:

- Before servicing, turn ignition switch OFF, disconnect battery negative terminal, and wait at least 3 minutes or more. (To discharge backup capacitor.)
- Never use unspecified tester or other measuring device.

#### 1. PERFORM COLLISION DIAGNOSIS

Perform collision diagnosis. Refer to [SR-5, "FOR FRONTAL COLLISION : When SRS is activated in a collision"](#) or [SR-6, "FOR FRONTAL COLLISION : When SRS is not activated in a collision"](#).

Is collision diagnosis complete?

- YES >> GO TO 2.  
NO >> INSPECTION END

#### 2. FINAL INSPECTION

Perform "AIR BAG" Self Diagnostic Result.

Is the inspection result normal?

# B1209 FRONTAL COLLISION DETECTION

## < DTC/CIRCUIT DIAGNOSIS >

---

YES >> INSPECTION END

NO >> Perform diagnosis of applicable DTC. Refer to [SRC-129, "DTC Index"](#).

A

B

C

D

E

F

G

**SRC**

I

J

K

L

M

N

O

P

# B1210 SIDE COLLISION DETECTION

< DTC/CIRCUIT DIAGNOSIS >

## B1210 SIDE COLLISION DETECTION

### Description

INFOID:000000006450450

#### DTC B1210 SIDE COLLISION DETECTION

When satellite sensor detects component damage resulting from a side collision, blinks or illuminates the air bag warning lamp to inform the driver. Malfunctioning can be detected by CONSULT-III.

#### OPERATION

The front side air bag and side curtain air bag are activated by the air bag diagnosis sensor unit signal transmitted at the time of the side collision.

#### STRUCTURE

It consists of satellite sensor, air bag diagnosis sensor unit, front side air bag and side curtain air bag.

#### INSTALLATION

Refer to [SE-188. "Exploded View"](#) (Front LH/RH side air bag module), [SR-19. "Exploded View"](#) (Side curtain air bag module), [SR-22. "Exploded View"](#) (LH/RH satellite sensor).

### DTC Logic

INFOID:000000006450451

DTC No.	Trouble diagnosis name	DTC detecting condition	Possible cause
B1210	SIDE COLLISION DETECTION	Front side air bag, side curtain air bag is deployed	—

### DTC CONFIRMATION PROCEDURE

#### 1. CHECK SELF-DIAG RESULT

With CONSULT-III

1. Turn ignition switch ON.
2. Perform "AIR BAG" Self Diagnostic Result.

Without CONSULT-III

1. Turn ignition switch ON.
2. Check the air bag warning lamp status. Refer to [SRC-14. "Air Bag Warning Lamp Diagnosis"](#).

#### NOTE:

SRS does not enter diagnosis mode if no malfunction is detected in user mode.

Is malfunctioning part detected?

- YES >> Refer to [SRC-128. "Diagnosis Procedure"](#).  
NO >> INSPECTION END

### Diagnosis Procedure

INFOID:000000006450452

#### WARNING:

- Before servicing, turn ignition switch OFF, disconnect battery negative terminal, and wait at least 3 minutes or more. (To discharge backup capacitor.)
- Never use unspecified tester or other measuring device.

#### 1. PERFORM COLLISION DIAGNOSIS

Perform collision diagnosis. Refer to [SR-7. "FOR SIDE AND ROLLOVER COLLISION : When SRS is activated in a collision"](#) or [SR-8. "FOR SIDE AND ROLLOVER COLLISION : When SRS is not activated in a collision"](#).

Is collision diagnosis complete?

- YES >> GO TO 2.  
NO >> INSPECTION END

#### 2. FINAL INSPECTION

Perform "AIR BAG" Self Diagnostic Result.

Is the inspection result normal?

- YES >> INSPECTION END  
NO >> Perform diagnosis of applicable DTC. Refer to [SRC-129. "DTC Index"](#).



# DIAGNOSIS SENSOR UNIT

< ECU DIAGNOSIS INFORMATION >

## ECU DIAGNOSIS INFORMATION

### DIAGNOSIS SENSOR UNIT

#### DTC Index

INFOID:000000006450453

Diagnostic item	Explanation	Reference page	
NO DTC IS DETECTED	When malfunction is indicated by the "AIR BAG" warning lamp in User mode	Low battery voltage (Less than 9 V)	<a href="#">SRC-142, "Diagnosis Procedure".</a>
		Self-diagnosis result "SELF-DIAG [PAST]" (previously stored in the memory) might not be erased after repair	<a href="#">SRC-14, "Air Bag Warning Lamp Diagnosis", SRC-18, "CONSULT-III Function".</a>
		Intermittent malfunction has been detected in the past	<a href="#">GI-43, "Intermittent Incident".</a>
	No malfunction is detected		—
CONTROL UNIT [B1001-B1015]	Air bag diagnosis sensor unit is malfunctioning or out of the specified specification	<ul style="list-style-type: none"> <li><a href="#">SRC-20, "DTC Logic".</a></li> <li><a href="#">SRC-22, "DTC Logic".</a></li> <li><a href="#">SRC-24, "DTC Logic".</a></li> </ul>	
OCCUPANT SENS C/U [UNIT FAIL] [B1017] [B1020] [B1021]	Malfunction occurs in Occupant Classification System control unit	<a href="#">SRC-26, "DTC Logic".</a>	
OCCUPANT SENS [UNIT FAIL] [B1018]	Malfunction occurs in Occupant Classification System sensor	<a href="#">SRC-28, "DTC Logic".</a>	
OCCUPANT SENS C/U [COMM FAIL] [B1022]	Malfunction occurs in Occupant Classification System control unit, circuit of Occupant Classification System control unit air bag diagnosis sensor unit, or air bag diagnosis sensor unit	<a href="#">SRC-30, "DTC Logic".</a>	
PASS A/B INDCTR CKT [B1023]	Front passenger air bag OFF indicator circuit is open or shorted to ground or the circuits are shorted each other	<a href="#">SRC-32, "DTC Logic".</a>	
CONTROL UNIT [B1026-B1031]	Air bag diagnosis sensor unit is malfunctioning or out of the specified specification	<a href="#">SRC-34, "DTC Logic".</a>	
CRASH ZONE SEN [UNIT FAIL] [B1033] [B1034]	Crash zone sensor is malfunctioning	<a href="#">SRC-36, "DTC Logic".</a>	
CRASH ZONE SEN [COMM FAIL] [B1035] [UNMATCH] [B1036]	Crash zone sensor is malfunctioning or out of the specified specification	<a href="#">SRC-38, "DTC Logic".</a>	
CONTROL UNIT [B1042-B1047]	Air bag diagnosis sensor unit is malfunctioning or out of the specified specification	<a href="#">SRC-40, "DTC Logic".</a>	
DRIVER AIRBAG MODULE [OPEN] [B1049] [B1054]	Driver air bag module circuit is open (including the spiral cable)	<a href="#">SRC-42, "DTC Logic".</a>	
DRIVER AIRBAG MODULE [VB-SHORT] [B1050] [B1055]	Driver air bag module circuit is shorted to some power supply circuit (including the spiral cable)	<a href="#">SRC-44, "DTC Logic".</a>	
DRIVER AIRBAG MODULE [GND-SHORT] [B1051] [B1056]	Driver air bag module circuit is shorted to ground (including the spiral cable)	<a href="#">SRC-46, "DTC Logic".</a>	

A

B

C

D

E

F

G

SRC

I

J

K

L

M

N

O

P

## DIAGNOSIS SENSOR UNIT

### < ECU DIAGNOSIS INFORMATION >

Diagnostic item	Explanation	Reference page
DRIVER AIRBAG MODULE [SHORT] [B1052] [B1057]	Driver air bag module circuits are shorted to each other (including spiral cable)	<a href="#">SRC-48, "DTC Logic"</a> .
CONTROL UNIT [B1058-B1063]	Air bag diagnosis sensor unit is malfunctioning or out of the specified specification	<a href="#">SRC-50, "DTC Logic"</a> .
ASSIST A/B MODULE [OPEN] [B1065] [B1070]	Front passenger air bag module circuit is open	<a href="#">SRC-52, "DTC Logic"</a> .
ASSIST A/B MODULE [VB-SHORT] [B1066] [B1071]	Front passenger air bag module circuit is shorted to some power supply circuit	<a href="#">SRC-54, "DTC Logic"</a> .
ASSIST A/B MODULE [GND-SHORT] [B1067] [B1072]	Front passenger air bag module circuit is shorted to ground	<a href="#">SRC-56, "DTC Logic"</a> .
ASSIST A/B MODULE [SHORT] [B1068] [B1073]	Front passenger air bag module circuits are shorted to each other	<a href="#">SRC-58, "DTC Logic"</a> .
CONTROL UNIT [B1074-B1079]	Air bag diagnosis sensor unit is malfunctioning or out of the specified specification	<a href="#">SRC-60, "DTC Logic"</a> .
PRE-TEN FRONT RH [OPEN] [B1081]	Front RH seat belt pre-tensioner circuit is open	<a href="#">SRC-62, "DTC Logic"</a> .
PRE-TEN FRONT RH [VB-SHORT] [B1082]	Front RH seat belt pre-tensioner circuit is shorted to some power supply circuit	<a href="#">SRC-64, "DTC Logic"</a> .
PRE-TEN FRONT RH [GND-SHORT] [B1083]	Front RH seat belt pre-tensioner circuit is shorted to ground	<a href="#">SRC-66, "DTC Logic"</a> .
PRE-TEN FRONT RH [SHORT] [B1084]	Front RH seat belt pre-tensioner circuits are shorted to each other	<a href="#">SRC-68, "DTC Logic"</a> .
PRE-TEN FRONT LH [OPEN] [B1086]	Front LH seat belt pre-tensioner circuit is open	<a href="#">SRC-70, "DTC Logic"</a> .
PRE-TEN FRONT LH [VB-SHORT] [B1087]	Front LH seat belt pre-tensioner circuit is shorted to some power supply circuit	<a href="#">SRC-72, "DTC Logic"</a> .
PRE-TEN FRONT LH [GND-SHORT] [B1088]	Front LH seat belt pre-tensioner circuit is shorted to ground	<a href="#">SRC-74, "DTC Logic"</a> .
PRE-TEN FRONT LH [SHORT] [B1089]	Front LH seat belt pre-tensioner circuits are shorted to each other	<a href="#">SRC-76, "DTC Logic"</a> .
CONTROL UNIT [B1106-B1111]	Air bag diagnosis sensor unit is malfunctioning or out of the specified specification	<a href="#">SRC-78, "DTC Logic"</a> .
SATELLITE SENS RH [UNIT FAIL] [B1113] [B1114]	RH satellite sensor is malfunctioning	<a href="#">SRC-80, "DTC Logic"</a> .

## DIAGNOSIS SENSOR UNIT

### < ECU DIAGNOSIS INFORMATION >

Diagnostic item	Explanation	Reference page	
SATELLITE SENS RH [COMM FAIL] [B1115] [UNMATCH] [B1116]	RH satellite sensor is malfunctioning or out of the specified specification	<a href="#">SRC-82, "DTC Logic"</a> .	A
SATELLITE SENS LH [UNIT FAIL] [B1118] [B1119]	LH satellite sensor is malfunctioning	<a href="#">SRC-84, "DTC Logic"</a> .	B
SATELLITE SENS LH [COMM FAIL] [B1120] [UNMATCH] [B1121]	LH satellite sensor is malfunctioning or out of the specified specification	<a href="#">SRC-86, "DTC Logic"</a> .	C
CONTROL UNIT [B1122-B1127]	Air bag diagnosis sensor unit is malfunctioning or out of the specified specification	<a href="#">SRC-88, "DTC Logic"</a> .	D
SIDE MODULE RH [OPEN] [B1129]	Front RH side air bag module circuit is open	<a href="#">SRC-90, "DTC Logic"</a> .	E
SIDE MODULE RH [VB-SHORT] [B1130]	Front RH side air bag module circuit is shorted to some power supply circuit	<a href="#">SRC-92, "DTC Logic"</a> .	F
SIDE MODULE RH [GND-SHORT] [B1131]	Front RH side air bag module circuit is shorted to ground	<a href="#">SRC-94, "DTC Logic"</a> .	G
SIDE MODULE RH [SHORT] [B1132]	Front LH seat belt pre-tensioner circuits are shorted to each other	<a href="#">SRC-96, "DTC Logic"</a> .	SRC
SIDE MODULE LH [OPEN] [B1134]	Front LH side air bag module circuit is open	<a href="#">SRC-98, "DTC Logic"</a> .	I
SIDE MODULE LH [VB-SHORT] [B1135]	Front LH side air bag module circuit is shorted to some power supply circuit	<a href="#">SRC-100, "DTC Logic"</a> .	J
SIDE MODULE LH [GND-SHORT] [B1136]	Front LH side air bag module circuit is shorted to ground	<a href="#">SRC-102, "DTC Logic"</a> .	K
SIDE MODULE LH [SHORT] [B1137]	Front LH side air bag module circuits are shorted to each other	<a href="#">SRC-104, "DTC Logic"</a> .	L
CURTAIN MODULE RH [OPEN] [B1145]	RH side curtain air bag module circuit is open	<a href="#">SRC-108, "DTC Logic"</a> .	M
CURTAIN MODULE RH [VB-SHORT] [B1146]	RH side curtain air bag module circuit is shorted to some power supply circuit	<a href="#">SRC-110, "DTC Logic"</a> .	N
CURTAIN MODULE RH [GND-SHORT] [B1147]	RH side curtain air bag module circuit is shorted to ground	<a href="#">SRC-112, "DTC Logic"</a> .	O
CURTAIN MODULE RH [SHORT] [B1148]	RH side curtain air bag module circuits are shorted to each other	<a href="#">SRC-114, "DTC Logic"</a> .	P
CURTAIN MODULE LH [OPEN] [B1150]	LH side curtain air bag module circuit is open	<a href="#">SRC-116, "DTC Logic"</a> .	

## DIAGNOSIS SENSOR UNIT

### < ECU DIAGNOSIS INFORMATION >

Diagnostic item	Explanation	Reference page
CURTAIN MODULE LH [VB-SHORT] [B1151]	LH side curtain air bag module circuit is shorted to some power supply circuits	<a href="#">SRC-118, "DTC Logic"</a> .
CURTAIN MODULE LH [GND-SHORT] [B1152]	LH side curtain air bag module circuit is shorted to ground	<a href="#">SRC-120, "DTC Logic"</a> .
CURTAIN MODULE LH [SHORT] [B1153]	LH side curtain air bag module circuits are shorted to each other	<a href="#">SRC-122, "DTC Logic"</a> .
CONTROL UNIT [B1202-B1207]	Air bag diagnosis sensor unit is malfunctioning or out of the specified specification	<a href="#">SRC-124, "DTC Logic"</a> .
FRONTAL COLLISION DETECTION [B1209]	Front seat belt pre-tensioner and front air bag is deployed	<a href="#">SRC-126, "DTC Logic"</a> .
SIDE COLLISION DE- TECTION [B1210]	Front side air bag and side curtain air bag are deployed	<a href="#">SRC-128, "DTC Logic"</a> .

# DIAGNOSIS SENSOR UNIT

< ECU DIAGNOSIS INFORMATION >

## Wiring Diagram - SRS AIR BAG CONTROL SYSTEM -

INFOID:000000006450454

### SRS AIR BAG CONTROL SYSTEM

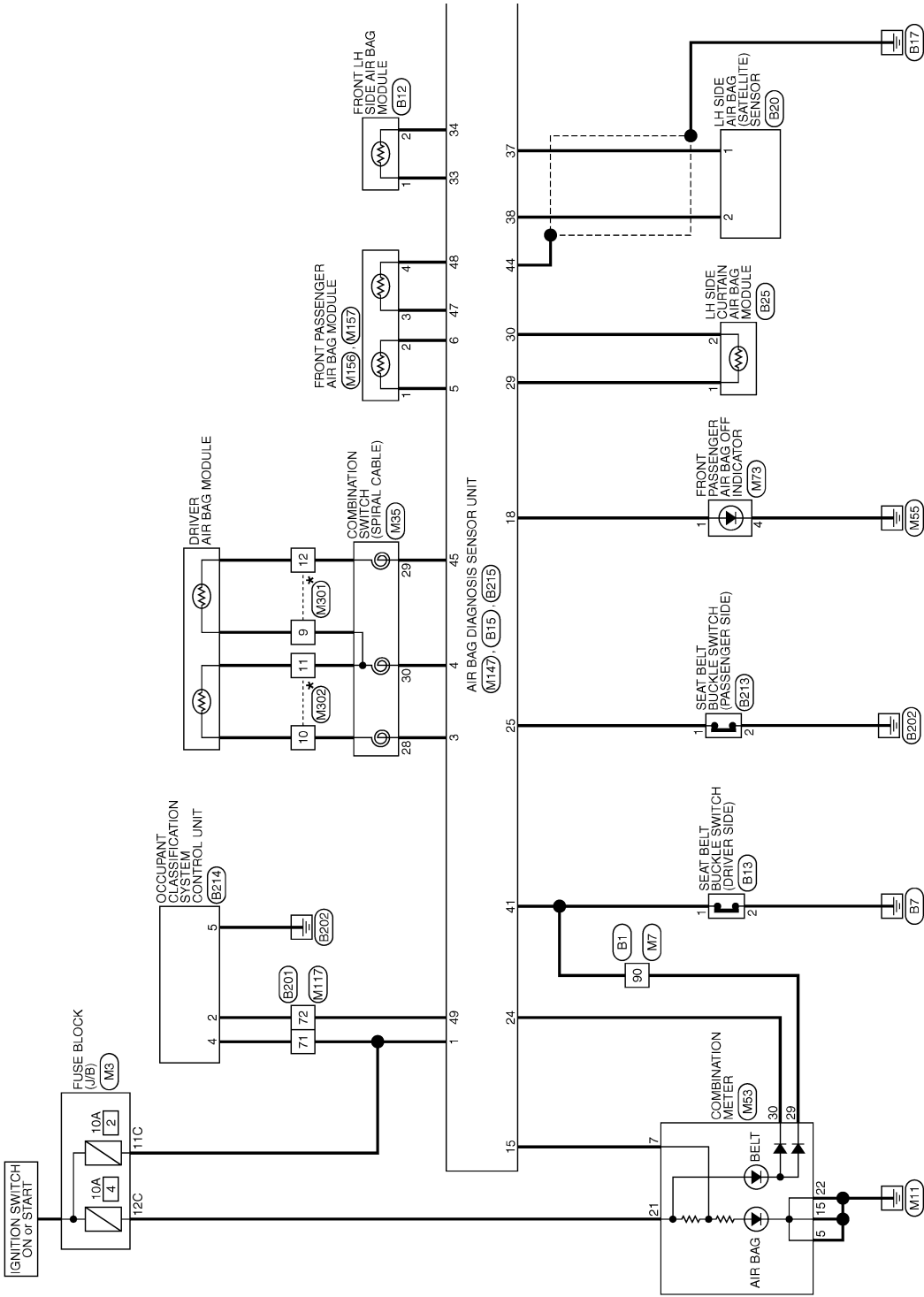

\*: This connector is not shown in "Harness Layout".

2010/10/07

JCHWM0856GB

A  
B  
C  
D  
E  
F  
G  
H  
I  
J  
K  
L  
M  
N  
O  
P

SRC

# DIAGNOSIS SENSOR UNIT

< ECU DIAGNOSIS INFORMATION >

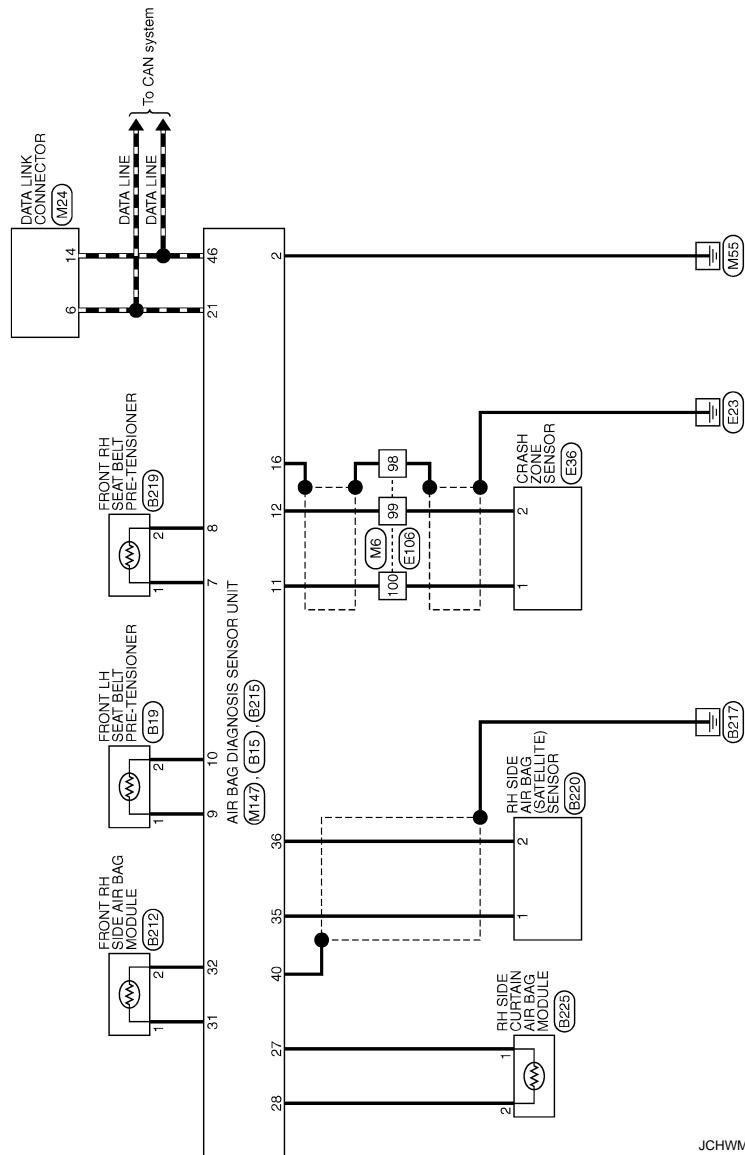

JCHWM0857GB

# DIAGNOSIS SENSOR UNIT

< ECU DIAGNOSIS INFORMATION >

## SRS AIR BAG CONTROL SYSTEM

Connector No.	B1
Connector Name	WIRE TO WIRE
Connector Type	TH80FN-CS16-TM4

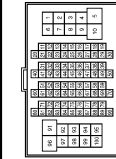

Terminal No.	Color of Wire	Signal Name [Specification]
1	GR	
2	G	
3	SB	
4	Y	
6	Y	
15	V	
16	BR	
17	LG	
18	W	
20	L	
21	P	
22	L	
23	P	
24	GR	
25	SB	
26	G	
27	W	
28	G	
31	V	
32	SB	
33	SHIELD	
34	W	
35	BR	
36	Y	
37	SHIELD	
38	Y	
39	LG	
40	P	
41	L	
42	SHIELD	
43	R	
44	G	
45	SHIELD	
46	SB	
48	L	
50	P	
55	P	
56	G	

58	V	
59	LG	
60	BR	
61	W	
62	R	
63	L	
64	Y	
65	SHIELD	
71	BR	
72	SB	
73	P	
74	L	
81	R	
82	B	
84	Y	
85	L	
86	GR	
87	R	
88	V	
89	GR	
91	Y	
95	EG	
96	R	
100	V	

Connector No.	B12
Connector Name	FRONT LH SIDE AIR BAG MODULE
Connector Type	TK02FY-EX-IV



Terminal No.	Color of Wire	Signal Name [Specification]
1	Y	
2	Y	

Connector No.	B13
Connector Name	SEAT BELT BUCKLE SWITCH (DRIVER SIDE)
Connector Type	A03FW

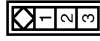

Terminal No.	Color of Wire	Signal Name [Specification]
1	GR	
2	B	

Connector No.	B15
Connector Name	AIR BAG DIAGNOSIS SENSOR UNIT
Connector Type	TK12FY-2V-EX

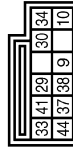

Terminal No.	Color of Wire	Signal Name [Specification]
9	Y	PLH (+)
10	Y	PLH (-)
28	LG	CLH (+)
29	LG	CLH (-)
30	Y	SLH (+)
33	Y	SLH (-)
34	P	SATELLITE LH (+)
37	P	SATELLITE LH (-)
38	L	LH BUCKLE SW INPUT
41	SB	
44	SHIELD	GND

Connector No.	B19
Connector Name	FRONT LH SEAT BELT PRE-TENSIONER
Connector Type	AGB02FY



Terminal No.	Color of Wire	Signal Name [Specification]
1	Y	
2	Y	

Connector No.	B20
Connector Name	LH SIDE AIR BAG (SATELLITE) SENSOR
Connector Type	HK02FY-IV-EX-LC



Terminal No.	Color of Wire	Signal Name [Specification]
1	P	
2	L	

Connector No.	B25
Connector Name	LH SIDE CURTAIN AIR BAG MODULE
Connector Type	AGB02FOR



Terminal No.	Color of Wire	Signal Name [Specification]
1	LG	
2	Y	

JCHWM0858GB

A  
B  
C  
D  
E  
F  
G  
H  
I  
J  
K  
L  
M  
N  
O  
P

SRC

# DIAGNOSIS SENSOR UNIT

< ECU DIAGNOSIS INFORMATION >

## SRS AIR BAG CONTROL SYSTEM

Connector No.	B201
Connector Name	WIRE TO WIRE
Connector Type	TH08FW-CS16-TM4

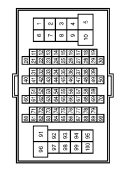

Terminal No.	Color of Wire	Signal Name [Specification]
1	GR	-
5	Y	G
6	Y	G
7	BG	G
9	LG	-
10	R	-
30	B	-
31	L	-
32	P	-
33	SB	-
34	V	-
40	GR	-
41	LG	-
42	BG	-
43	R	-
45	G	-
46	SHIELD	-
47	G	-
48	Y	-
48	SHIELD	-
50	P	-
50	BG	-
71	R	-
72	V	-
80	V	-
81	SHIELD	-
82	Y	-
83	BR	-
84	O	-
85	SHIELD	-
86	G	-
87	R	-
88	W	-
89	B	-
90	SB	-
91	V	-
94	W	-
95	G	-

97	BR	-
----	----	---

Connector No.	B212
Connector Name	FRONT RH SIDE AIR BAG MODULE
Connector Type	TK02FY-EX-1V



Terminal No.	Color of Wire	Signal Name [Specification]
1	Y	-
2	Y	-

Connector No.	B213
Connector Name	SEAT BELT BUCKLE SWITCH (PASSENGER SIDE)
Connector Type	AC03FW

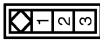

Terminal No.	Color of Wire	Signal Name [Specification]
1	LG	-
2	B	-

Connector No.	B214
Connector Name	OCCUPANT CLASSIFICATION SYSTEM CONTROL UNIT
Connector Type	TH08FW-NH

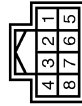

Terminal No.	Color of Wire	Signal Name [Specification]
2	V	COMMUNICATION
4	R	GND
5	B	GND

Connector No.	B215
Connector Name	AIR BAG DIAGNOSIS SENSOR UNIT
Connector Type	TK12FY-1V-EX

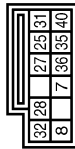

Terminal No.	Color of Wire	Signal Name [Specification]
7	Y	PR1 (+)
8	Y	PR1 (-)
25	LG	RH BUCKLE SW INPUT
27	LG	CRH (+)
28	Y	CRH (-)
31	Y	SRH (+)
32	Y	SRH (-)
35	G	SATELLITE RH (+)
36	R	SATELLITE RH (-)
40	SHIELD	GND

Connector No.	B219
Connector Name	FRONT RH SEAT BELT PRE-TENSIONER
Connector Type	AC030FY



Terminal No.	Color of Wire	Signal Name [Specification]
1	Y	-
2	Y	-

Connector No.	B220
Connector Name	RH SIDE AIR BAG (SATELLITE) SENSOR
Connector Type	HK02FY-1V-EX-LC



Terminal No.	Color of Wire	Signal Name [Specification]
1	G	-
2	R	-

Connector No.	B225
Connector Name	RH SIDE CURTAIN AIR BAG MODULE
Connector Type	AC030FY



Terminal No.	Color of Wire	Signal Name [Specification]
1	LG	-
2	Y	-

Connector No.	E06
Connector Name	CRASH ZONE SENSOR
Connector Type	HK02FY-1V-EX-LC



Terminal No.	Color of Wire	Signal Name [Specification]
1	P	-
2	L	-

JCHWM0859GB



# DIAGNOSIS SENSOR UNIT

< ECU DIAGNOSIS INFORMATION >

## SRS AIR BAG CONTROL SYSTEM

Connector No.	E106
Connector Name	WIRE TO WIRE
Connector Type	TH80FW-CS1.6-TM4

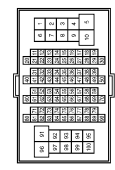

Terminal No.	Color of Wire	Signal Name [Specification]
1	GR	-
3	EG	-
5	G	-
6	EG	-
7	V	- [With daytime running light]
7	LG	- [Without daytime running light]
9	L	- [With daytime running light]
9	R	- [Without daytime running light]
10	W	-
11	V	-
12	R	-
13	L	-
14	GR	-
15	P	-
16	W	-
17	V	-
18	EG	-
19	GR	-
20	LG	-
30	R	-
31	L	-
32	EG	-
33	P	-
34	V	-
35	BR	-
36	W	-
37	Y	-
38	R	-
39	B	-
40	G	-
41	W	-
42	LG	-
43	SB	-
44	GR	-
45	EG	-
46	LG	-
47	V	-
48	P	-

49	L	-
59	B	-
66	LG	-
67	SB	-
68	R	-
69	W	-
70	G	-
80	W	-
81	P	-
82	G	-
83	V	-
84	L	-
85	BG	-
86	LG	-
87	Y	-
88	GR	-
89	W	-
91	G	-
93	GR	-
95	Y	-
96	W	-
97	BR	-
98	SHIELD	-
99	L	-
100	P	-

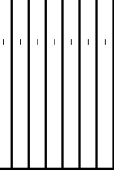

Connector No.	M3
Connector Name	FUSE BLOCK (J/B)
Connector Type	NS12FW-CS



Terminal No.	Color of Wire	Signal Name [Specification]
6C	SB	-
7C	B	-
8C	W	-
9C	EG	-
10C	L	-
11C	LG	-
12C	G	-

Connector No.	M6
Connector Name	WIRE TO WIRE
Connector Type	TH82MW-CS1.6-TM4

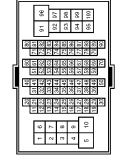

Terminal No.	Color of Wire	Signal Name [Specification]
1	BG	-
3	R	-
5	G	-
6	LG	-
7	W	-
9	G	-
10	W	-
11	V	-
12	R	-
13	L	-
14	GR	-
15	P	-
16	W	-
17	BR	-
18	P	-
19	L	-
20	L	-
30	BR	-
31	L	-
32	Y	-
33	BG	-
34	W	-
35	BR	-
36	R	-
37	Y	-
38	R	-
39	SB	-
40	G	-
41	V	-
42	LG	-
43	P	-
44	B	- [With A/T]
44	R	- [With M/T]
45	BG	-
46	G	-
47	L	-
48	P	-
48	L	-

59	B	-
66	Y	-
67	G	-
68	R	-
69	W	-
70	G	-
80	SB	-
81	B	-
82	V	-
83	W	-
84	L	-
85	GR	-
86	G	-
87	R	-
88	B	-
89	LG	-
91	W	-
93	Y	-
95	Y	-
96	R	-
97	GR	-
98	SHIELD	-
99	V	-
100	SB	-

A  
B  
C  
D  
E  
F  
G  
H  
I  
J  
K  
L  
M  
N  
O  
P

SRC

# DIAGNOSIS SENSOR UNIT

< ECU DIAGNOSIS INFORMATION >

## SRS AIR BAG CONTROL SYSTEM

Connector No.	M7
Connector Name	WIRE TO WIRE
Connector Type	TH04MW-CS1E-TM4



Terminal No.	Color of Wire	Signal Name [Specification]
1	GR	-
2	P	-
3	P	- [With automatic drive positioner]
4	Y	- [Without automatic drive positioner]
6	L	-
15	R	-
16	BR	-
17	P	-
18	Y	-
20	L	-
21	P	-
22	L	-
23	P	-
24	V	-
25	LG	-
26	BR	-
27	BG	-
28	LG	-
31	V	-
32	LG	-
33	SHIELD	-
34	GR	-
35	BR	-
36	Y	-
37	SHIELD	-
38	SB	-
39	LG	-
40	O	-
41	W	-
42	SHIELD	-
43	R	-
44	G	-
45	SHIELD	-
46	SB	-
48	L	-
50	P	-
55	W	-

56	B	-
58	V	-
59	Y	-
60	Y	-
61	W	-
62	R	-
63	G	-
64	B	-
65	SHIELD	-
71	V	-
72	P	-
73	SB	-
74	V	-
81	W	-
82	BR	-
84	LG	-
85	BG	-
86	SB	-
87	G	-
88	GR	-
89	P	-
91	BG	-
95	BG	-
96	Y	-
100	P	-

Connector No.	M24
Connector Name	DATA LINK CONNECTOR
Connector Type	BD16FW-P

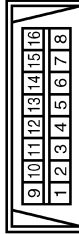

Terminal No.	Color of Wire	Signal Name [Specification]
3	LG	-
4	B	-
5	B	-
6	L	-
7	V	-
8	G	-
11	SB	-
14	P	-
16	R	-

Connector No.	M35
Connector Name	COMBINATION SWITCH (SPIRAL CABLE)
Connector Type	TKGBFY-EX-1V



Terminal No.	Color of Wire	Signal Name [Specification]
23	R	-
28	Y	-
29	Y	-
30	Y	-

Connector No.	M53
Connector Name	COMBINATION METER
Connector Type	IS4546FW



Terminal No.	Color of Wire	Signal Name [Specification]
1	V	BATTERY POWER SUPPLY
2	LG	COMMUNICATION SIGNAL (METER->AMP)
3	GR	COMMUNICATION SIGNAL (AMP->METER)
5	B	GROUND
6	W	ALTERNATOR SIGNAL
7	LG	AIR BAG SIGNAL
10	W	SECURITY SIGNAL
15	B	GROUND
16	BR	METER CONTROL SWITCH GROUND
18	GR	ILL GND
19	B	ILL GND
20	R	ILL
21	G	IGNITION SIGNAL
22	B	GROUND
24	BR	COMMUNICATION SIGNAL (LCD->AMP)
25	Y	COMMUNICATION SIGNAL (AMP->LCD)
26	R	VEHICLE SPEED SIGNAL (8-PULSE)
27	P	PARKING BRAKE SWITCH SIGNAL

28	SB	BRAKE FLUID LEVEL SWITCH
29	P	SEAT BELT BUCKLE SW SIGNAL (DRIVER SIDE)
30	G	SEAT BELT BUCKLE SWITCH SIGNAL (PASSENGER SIDE)
31	L	WASHER LEVEL SWITCH SIGNAL
33	R	ILLUMINATION CONTROL SIGNAL
36	LG	ENTER SWITCH SIGNAL
37	Y	SELECT SWITCH SIGNAL
38	G	TRIP A/B RESET SWITCH SIGNAL
39	P	ILLUMINATION CONTROL SWITCH SIGNAL (-)
40	BG	ILLUMINATION CONTROL SWITCH SIGNAL (+)

Connector No.	M73
Connector Name	FRONT PASSENGER AIR BAG OFF INDICATOR
Connector Type	TH04MW-FH



Terminal No.	Color of Wire	Signal Name [Specification]
1	R	-
4	B	-

# DIAGNOSIS SENSOR UNIT

< ECU DIAGNOSIS INFORMATION >

## SRS AIR BAG CONTROL SYSTEM

Connector No.	M117
Connector Name	WIRE TO WIRE
Connector Type	TH80MW-CS (F-TM4)

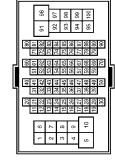

Terminal No.	Color of Wire	Signal Name [Specification]
1	LG	-
5	P	-
6	G	-
7	SB	-
8	LG	-
10	L	-
30	B	-
31	SB	-
32	LG	-
33	SB	-
34	LG	-
40	Y	-
41	G	-
42	LG	-
43	R	-
45	G	-
46	SHIELD	-
47	P	-
48	L	-
48	SHIELD	-
50	W	-
56	R	-
71	R	-
72	L	-
80	W	-
81	SHIELD	-
82	P	-
83	L	-
84	G	-
85	SHIELD	-
86	W	-
87	B	-
88	R	-
89	G	-
90	Y	-
91	V	-
94	Y	-
95	G	-

97	R	-
----	---	---

Connector No.	M147
Connector Name	AIR BAG DIAGNOSIS SENSOR UNIT
Connector Type	TK2BFY-EX-SC

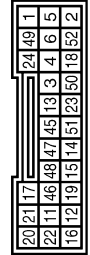

Terminal No.	Color of Wire	Signal Name [Specification]
1	LG	IGN
2	B	GND
3	Y	DR 1 (+)
4	Y	DR 1 (-) DR 2 (-)
5	Y	AS 1 (+)
6	Y	AS 1 (-)
11	SB	EGZS (+)
12	V	EGZS (-)
15	LG	AIR BAG W/L
16	SHIELD	GND
18	R	OUTOFF TELLTALE
21	L	CAN-H
24	G	SEAT BELT
45	Y	DR 2 (+)
46	P	CAN-L
47	Y	AS 2 (+)
48	Y	AS 2 (-)
49	L	ODS INPUT

2	Y	-
---	---	---

Connector No.	M157
Connector Name	FRONT PASSENGER AIR BAG MODULE
Connector Type	JCA02FOR



Terminal No.	Color of Wire	Signal Name [Specification]
3	Y	-
4	Y	-

Connector No.	M301
Connector Name	DRIVER AIR BAG MODULE
Connector Type	ACA02FOR



Terminal No.	Color of Wire	Signal Name [Specification]
9	-	-
12	-	-

Connector No.	M302
Connector Name	DRIVER AIR BAG MODULE
Connector Type	ACA02FY-2V



Terminal No.	Color of Wire	Signal Name [Specification]
10	-	-
11	-	-

A  
B  
C  
D  
E  
F  
G  
H  
I  
J  
K  
L  
M  
N  
O  
P

SRC

# SRS AIR BAG WARNING LAMP DOES NOT TURN OFF

< SYMPTOM DIAGNOSIS >

---

## SYMPTOM DIAGNOSIS

### SRS AIR BAG WARNING LAMP DOES NOT TURN OFF

#### Diagnosis Procedure

INFOID:000000006450455

#### 1. CHECK FRONT AIR BAG MODULE

---

Check the deployment of front air bag module.

Is air bag module deployed?

YES >> Refer to [SR-11](#) or [SR-17, "Exploded View"](#).

NO >> GO TO 2.

#### 2. CHECK AIR BAG FUSE

---

Check the air bag fuse. Refer to [PG-122, "Fuse and Fusible Link Arrangement"](#).

Is 10A fuse [No.2, located in fuse block (J/B)] normal?

YES >> GO TO 4.

NO >> GO TO 3.

#### 3. CHECK AIR BAG FUSE AGAIN

---

Replace air bag fuse and turn ignition switch ON.

Did the air bag fuse blow again?

YES >> Repair or replace main harness.

NO >> **INSPECTION END**

#### 4. CHECK DIAGNOSIS SENSOR UNIT

---

Check the screen of CONSULT-III.

Is the inspection result normal?

YES >> GO TO 5.

NO >> Replace diagnosis sensor unit (ACU). Refer to [SR-23, "Exploded View"](#).

#### 5. CHECK HARNESS CONNECTION

---

Check harness connection between air bag warning lamp and diagnosis sensor unit.

Is the inspection result normal?

YES >> Check the intermittent incident. Refer to [GI-43, "Intermittent Incident"](#).

NO >> Replace wiring harness connector.

# SRS AIR BAG WARNING LAMP DOES NOT TURN ON

< SYMPTOM DIAGNOSIS >

## SRS AIR BAG WARNING LAMP DOES NOT TURN ON

### Diagnosis Procedure

INFOID:000000006450456

"SRS AIR BAG" Warning Lamp Does Not Turn ON

#### 1. CHECK METER FUSE

Check the meter fuse. Refer to [PG-122, "Fuse and Fusible Link Arrangement"](#).

Is 10A fuse [No.4, located in fuse block (J/B)] normal?

YES >> GO TO 3.

NO >> GO TO 2.

#### 2. CHECK METER FUSE AGAIN

Replace 10A fuse [No.4, located in fuse block (J/B)] and turn ignition switch ON.

Did the meter fuse blow again?

YES >> Repair or replace the related harness.

NO >> **INSPECTION END**

#### 3. CHECK HARNESS CONNECTION

1. Check harness connection between diagnosis sensor unit and combination meter.

2. Disconnect diagnosis sensor unit connector and turn ignition switch ON.

Did air bag warning lamp turn ON?

YES >> Replace diagnosis sensor unit (ACU). Refer to [SR-23, "Exploded View"](#).

NO >> Replace combination meter assembly. Refer to [MWI-130, "Removal and Installation"](#).

A  
B  
C  
D  
E  
F  
G  
I  
J  
K  
L  
M  
N  
O  
P

SRC

# SRS AIR BAG WARNING LAMP BLINKS

< SYMPTOM DIAGNOSIS >

---

## SRS AIR BAG WARNING LAMP BLINKS

### Diagnosis Procedure

INFOID:000000006920990

#### 1. CHECK BATTERY

---

Check battery. Refer to [PG-3, "How to Handle Battery"](#).

Is the inspection result normal?

YES >> GO TO 2.

NO >> Repair or replace malfunctioning parts.

#### 2. REPLACE OCCUPANT CLASSIFICATION SYSTEM CONTROL UNIT

---

1. Replace occupant classification system control unit. Refer to [SR-26, "Removal and Installation"](#).

2. Check air bag warning lamp operation.

Is the inspection result normal?

YES >> INSPECTION END

NO >> GO TO 3.

#### 3. REPLACE AIR BAG DIAGNOSIS SENSOR UNIT

---

1. Replace air bag diagnosis sensor unit. Refer to [SR-23, "Removal and Installation"](#).

2. Check air bag warning lamp operation.

Is the inspection result normal?

YES >> INSPECTION END

NO >> GO TO 1.

# PASSENGER SEAT BELT WARNING SYSTEM

< SYMPTOM DIAGNOSIS >

## PASSENGER SEAT BELT WARNING SYSTEM

### Diagnosis Procedure

INFOID:000000006450457

#### 1.CHECK THE SYSTEM 1

Check the seat belt warning lamp function.

Sea tbelt warning lamp turns ON in the following conditions.

- Driver seat belt is fastened.
- Occupant is on passenger seat.
- Passenger seat belt is not fasten.

Is the inspection result normal?

YES >> GO TO 2.

NO >> Check the followings.

- Harness between air bag diagnosis sensor unit and combination meter.
- Seat belt buckle switch (passenger side) circuit.
- Seat belt buckle switch (passenger side).

If these are OK, replace air bag diagnosis sensor unit.

#### 2.CHECK THE SYSTEM 2

Check the seat belt warning lamp function.

Seat belt warning lamp turns OFF in the following conditions.

- Driver seat belt is fastened.
- Occupant is on passenger seat.
- Passenger seat belt is fastened.

Is the inspection result normal?

YES >> System is OK.

NO >> Check the followings.

- Seat belt buckle switch (passenger side) circuit.
- Seat belt buckle switch (passenger side).

If these are OK, replace air bag diagnosis sensor unit.

A

B

C

D

E

F

G

SRC

I

J

K

L

M

N

O

P

# PRECAUTIONS

< PRECAUTION >

## PRECAUTION

### PRECAUTIONS

#### Precaution for Supplemental Restraint System (SRS) "AIR BAG" and "SEAT BELT PRE-TENSIONER"

INFOID:000000006450458

The Supplemental Restraint System such as "AIR BAG" and "SEAT BELT PRE-TENSIONER", used along with a front seat belt, helps to reduce the risk or severity of injury to the driver and front passenger for certain types of collision. This system includes seat belt switch inputs and dual stage front air bag modules. The SRS system uses the seat belt switches to determine the front air bag deployment, and may only deploy one front air bag, depending on the severity of a collision and whether the front occupants are belted or unbelted. Information necessary to service the system safely is included in the "SRS AIR BAG" and "SEAT BELT" of this Service Manual.

#### **WARNING:**

**Always observe the following items for preventing accidental activation.**

- **To avoid rendering the SRS inoperative, which could increase the risk of personal injury or death in the event of a collision that would result in air bag inflation, all maintenance must be performed by an authorized NISSAN/INFINITI dealer.**
- **Improper maintenance, including incorrect removal and installation of the SRS, can lead to personal injury caused by unintentional activation of the system. For removal of Spiral Cable and Air Bag Module, see "SRS AIR BAG".**
- **Never use electrical test equipment on any circuit related to the SRS unless instructed to in this Service Manual. SRS wiring harnesses can be identified by yellow and/or orange harnesses or harness connectors.**

#### PRECAUTIONS WHEN USING POWER TOOLS (AIR OR ELECTRIC) AND HAMMERS

#### **WARNING:**

**Always observe the following items for preventing accidental activation.**

- **When working near the Air Bag Diagnosis Sensor Unit or other Air Bag System sensors with the ignition ON or engine running, never use air or electric power tools or strike near the sensor(s) with a hammer. Heavy vibration could activate the sensor(s) and deploy the air bag(s), possibly causing serious injury.**
- **When using air or electric power tools or hammers, always switch the ignition OFF, disconnect the battery, and wait at least 3 minutes before performing any service.**

#### Service

INFOID:000000006450459

- Do not use electrical test equipment to check SRS circuits unless instructed to in this Service Manual.
- Before servicing the SRS, turn ignition switch OFF, disconnect both battery cables and wait at least 3 minutes.  
For approximately 3 minutes after the cables are removed, it is still possible for the air bag and seat belt pretensioner to deploy. Therefore, do not work on any SRS connectors or wires until at least 3 minutes have elapsed.
- Diagnosis sensor unit must always be installed with their arrow marks "←" pointing towards the front of the vehicle for proper operation. Also check diagnosis sensor unit for cracks, deformities or rust before installation and replace as required.
- The spiral cable must be aligned in the neutral position since its rotations are limited. Do not turn steering wheel and column after removal of steering gear.
- Handle air bag module carefully. Always place driver and front passenger air bag modules with the pad side facing upward and seat mounted front side air bag module standing with the stud bolt side facing down.
- Conduct self-diagnosis to check entire SRS for proper function after replacing any components.
- After air bag inflates, the front instrument panel assembly should be replaced if damaged.
- Always replace instrument panel pad following front passenger air bag deployment.

#### Precaution for Battery Service

INFOID:000000006450460

Before disconnecting the battery, lower both the driver and passenger windows. This will prevent any interference between the window edge and the vehicle when the door is opened/closed. During normal operation, the window slightly raises and lowers automatically to prevent any window to vehicle interference. The automatic window function will not work with the battery disconnected.



# PRECAUTIONS

< PRECAUTION >

## Occupant Classification System

INFOID:000000006450461

- Replace occupant classification system control unit and passenger front seat cushion as an assembly.  
Refer to [SE-191. "Removal and Installation"](#).

A

B

C

D

E

F

G

**SRC**

I

J

K

L

M

N

O

P